

Features

- Low Voltage Operation (1.8 V to 3.3 V)
- Low On-Resistance - r_{ON} : 1.8 Ω at 2.7 V
- Low Charge Injection
- Low Voltage Logic Compatible
- DFN-6 Package or SC70-6 Package

Benefits

- Reduced Power Consumption
- Simple Logic Interface
- High Accuracy
- Reduce Board Space
- Guaranteed 2 V Operation

Applications

- Cellular Phones
- Communication Systems
- Portable Test Equipment
- Battery Operated Systems
- Sample and Hold Circuits
- ADC and DAC Applications
- USB 1.1 Interfaces

Description

The PA2011 is a low on-resistance, single-pole double-throw monolithic CMOS analog switch. It is designed for low voltage applications with guaranteed operation at 2 V.

The PA2011 is ideal for portable and battery powered equipment, requiring high performance and efficient use of board space. In addition to the low on-resistance (1.8 Ω at 2.7 V), charge injection is less than 10 pC over the entire analog range.

The switch conducts equally well in both directions when on, and blocks up to the power supply level when off.

Break-before-make is guaranteed.

The PA2011 is mounted in a 1.6 x 1.6 mm DFN-6 or SC70-6 lead package, reducing board spacing by approximately 40 %

Pin Configuration

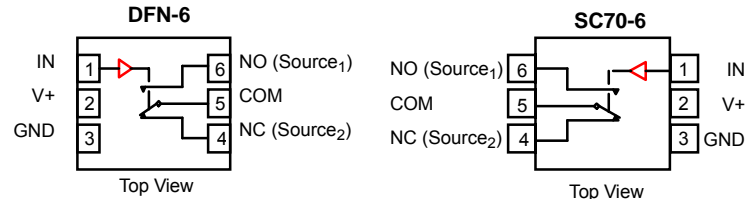

Truth Table		
Logic	NC	NO
0	ON	OFF
1	OFF	ON

Ordering information		
Temp. Range	Package	Part Number
-40 to 85 °C	DFN-6	PA2011DN-T7
	SC70-6	PA2011SC-T7

Typical Application

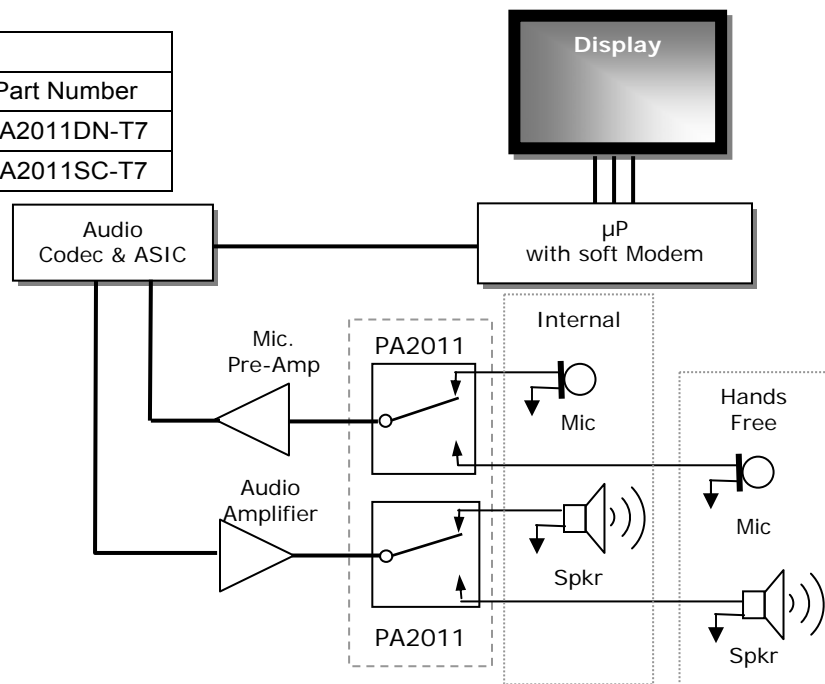

Absolute Maximum Ratings T _A = 25 °C, unless otherwise noted		
Parameter	Limit	Unit
Reference V+ to Ground	-0.3 to 4.2	V
IN, COM, NC, NO ¹	-0.3 to (V _{CC} + 0.3V)	
Continuous Current (NO,NC,COM pins)	±150	mA
Peak Current (Pulsed at 1mS, 10% duty cycle)	±300	
Storage Temperature	-65 to +150	°C
Power Dissipation	172	mW

Notes

1. Signals on NC, NO, or COM or IN exceeding V+ will be clamped by internal diodes. Limit forward diode current to maximum current ratings

Specifications V+ = 2.0V Test Conditions unless otherwise specified: V+ = 2.0 V, V_{IN} = 0.4 V or 1.6 V

Parameter	Symbol	Test Conditions	Temp	Min	Typ	Max	Unit
Analog Switch							
Analog Signal Range	V _{NO} , V _{NC} , V _{COM}		Full	0.0		V _{CC}	V
On-Resistance	R _{ON}	V _{CC} = 2.0V, V _{COM} = 0.2V- 0.9V I _{NO} , I _{NC} = 20mA,	Room Full		3.5	5.5 5.5	Ω
Switch Off Leakage Current	I _{OFF(NO)} or I _{OFF(NC)}	V+ = 2.2 V, V _{NO} , V _{NC} = 0.5 V/1.5 V, V _{COM} = 1.5 V/0.5 V	Room Full	-1 -10		-1 -10	nA
	I _{COM(OFF)}	V+ = 2.2 V, V _{NO} , V _{NC} = 0.5 V/1.5 V, V _{COM} = 1.5 V/0.5 V	Room Full	-1 -10		-1 -10	
Channel On Leakage Current	I _{COM(ON)}	V+ = 2.2 V, V _{NO} , V _{NC} = V _{COM} = 0.5 V/1.5 V	Room Full	-1 -10		-1 -10	
Digital Control							
Input High Voltage	V _{INH}		Full	1.5			VnA
Input Low Voltage	V _{INL}		Full			0.4	
Input Capacitance	C _{in}		Full		4		pF
Input Current	I _{INL} or I _{INH}	V _{IN} = 0 or V+	Full	1		1	μA
Dynamic Characteristics							
Turn On Time	t _{ON}	V _{NO} or V _{NC} = 1.5 V, R _L = 300 Ω, C _L = 35 pF	Room Full		75	110 113	nS
Turn Off Time	t _{OFF}		Room Full		37	71 76	
Break Before Make Time	t _{BBM}		Room Full		37		
Charge Injection	Q _{INJ}		Room		7		pC
Off Isolation	OIRR		Room		-62		dB
Crosstalk	X _{TALK}		Room		-69		
NO, NC OFF Capacitance	C _{NO(off)} C _{NC(off)}		Room		29		pF
Channel On Capacitance	C _{ON}		Room		85		
Power Supply							
Positive Supply Range	V+	V _{IN} = 0 or V+		1.8		3.3	V
Negative Supply Current	I+				0.01		1.0

Specifications V+ = 3.0V Test Conditions unless otherwise specified: $V+ = 3.0V \pm 10\%$, $V_{IN} = 0.4 V$ or $2.0V$

Parameter	Symbol	Test Conditions	Temp	Min	Typ	Max	Unit
Analog Switch							
Analog Signal Range	V_{NO}, V_{NC}, V_{COM}		Full	0.0		V_{CC}	V
On-Resistance	R_{ON}	$V_{CC} = 2.7V, V_{COM} = 0.9V - 1.5V$ $I_{NO}, I_{NC} = 50mA,$	Room		1.8	2.7	Ω
R_{ON} Matching	ΔR_{ON}		Full			0.2	
R_{ON} Flatness	$R_{ON(FLAT)}$				0.2	0.5	
Switch Off Leakage Current	$I_{OFF(NO)}$ or $I_{OFF(NC)}$	$V+ = 3.3 V,$ $V_{NO}, V_{NC} = 1.0 V/3.0 V, V_{COM} = 3.0 V/1.0 V$	Room	-1		-1	nA
	$I_{COM(OFF)}$		Full	-10		-10	
Channel On Leakage Current	$I_{COM(ON)}$	$V+ = 3.3 V, V_{NO}, V_{NC} = V_{COM} = 1.0V/3.0 V$	Room	-1		-1	
			Full	-10		-10	
Digital Control							
Input High Voltage	V_{INH}		Full	1.5			VnA
Input Low Voltage	V_{INL}		Full			0.4	
Input Capacitance	C_{in}		Full		4		pF
Input Current	I_{INL} or I_{INH}	$V_{IN} = 0$ or $V+$	Full	1		1	μA
Dynamic Characteristics							
Turn On Time	t_{ON}	V_{NO} or $V_{NC} = 2.0 V, R_L = 300 \Omega, C_L = 35 pF$	Room		45	75	nS
Turn Off Time	t_{OFF}		Full		29	59	
Break Before Make Time	t_{BBM}		Full		16	62	
Charge Injection	Q_{INJ}	$C_L = 1 nF, V_{GEN} = 0 V, R_{GEN} = 0 \Omega$	Room		2		pC
Off Isolation	OIRR	$R_L = 50 \Omega, C_L = 5 pF, f = 1 MHz$	Room		-62		dB
Crosstalk	X_{TALK}		Room		-69		
NO, NC OFF Capacitance	$C_{NO(off)}$ $C_{NC(off)}$	$V_{IN} = 0$ or $V+, f = 1 MHz$	Room		28		pF
Channel On Capacitance	C_{ON}		Room		84		
Power Supply							
Positive Supply Range	V+	$V_{IN} = 0$ or $V+$		1.8		3.3	V
Negative Supply Current	I+				0.01		1.0

Notes:

1. Room = 25 °C, Full = as determined by the operating suffix.
2. Typical values are for design aid only, not guaranteed nor subject to production testing.
3. The algebraic convention whereby the most negative value is a minimum and the most positive a maximum, is used in this data sheet.
4. Guarantee by design, not subjected to production test.
5. V_{IN} = input voltage to perform proper function.
6. Guaranteed by 5 V leakage testing, not production tested.

Typical Characteristics T_A = 25 °C, unless otherwise noted

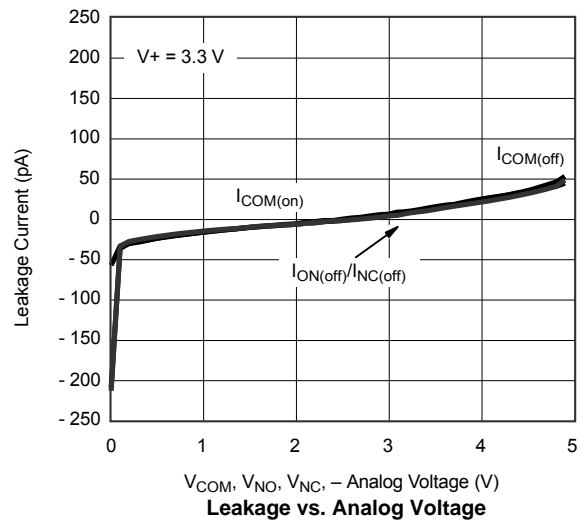
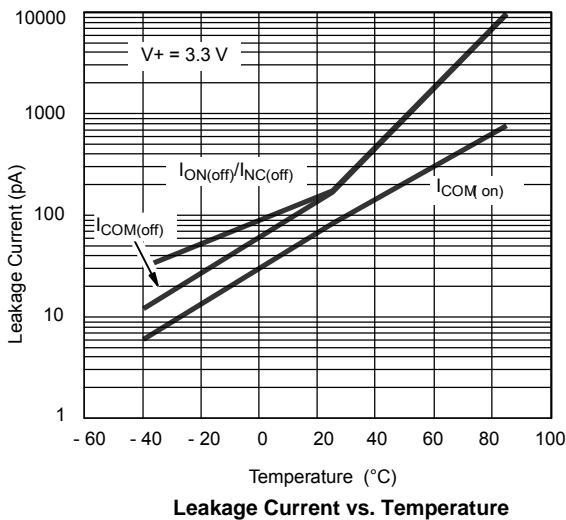
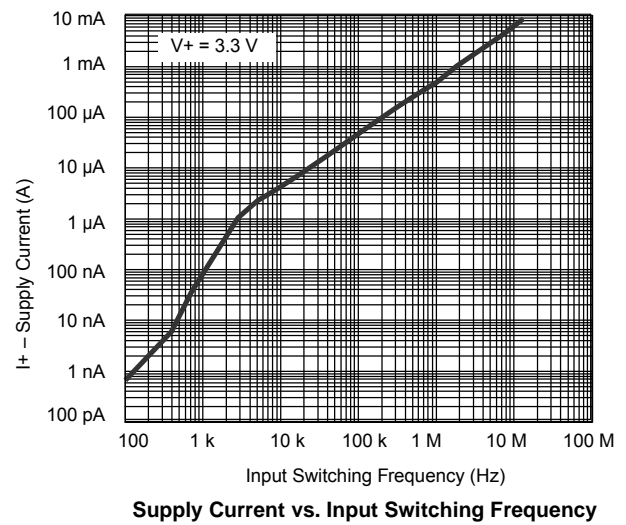
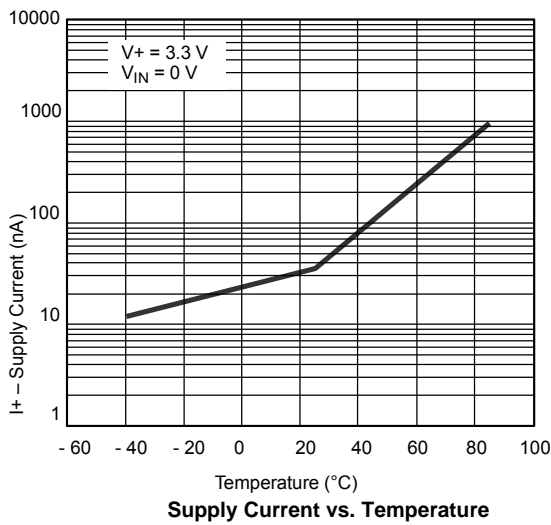
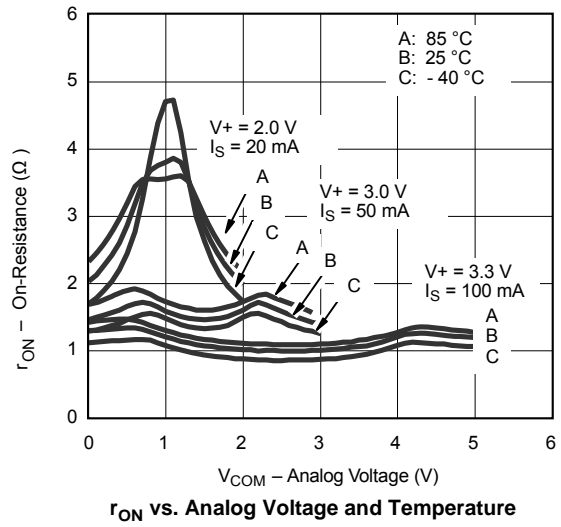
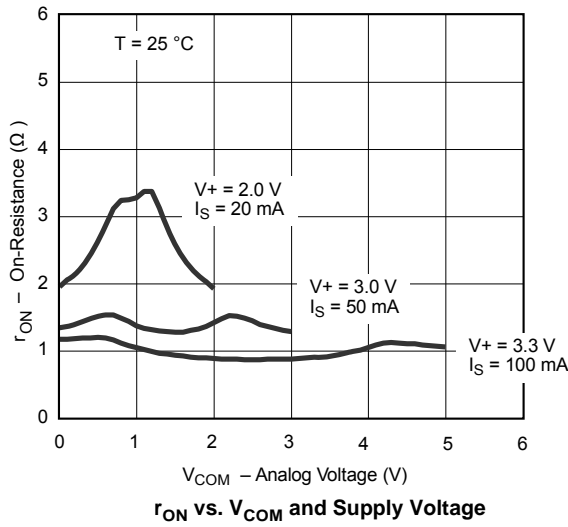

Typical Characteristics T_A = 25 °C, unless otherwise noted

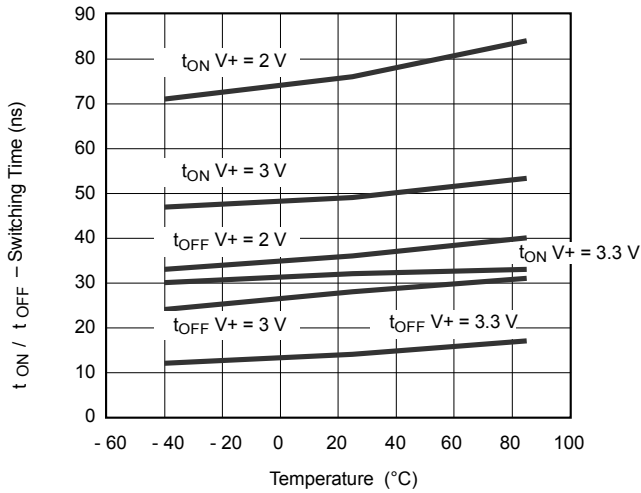

Switching Time vs. Temperature and Supply Voltage

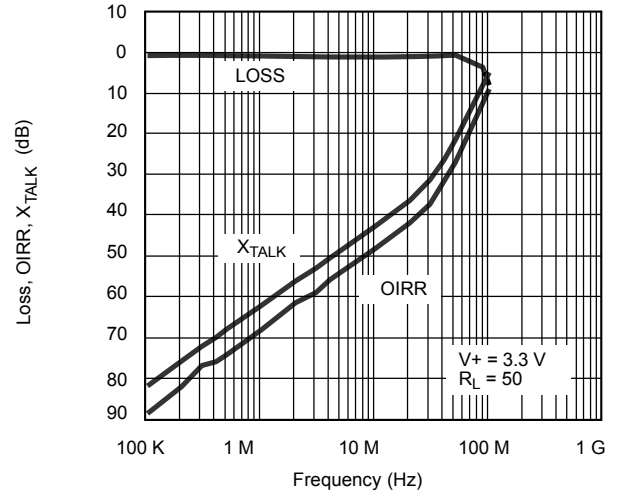

Insertion Loss, Off-Isolation, Crosstalk vs. Frequency

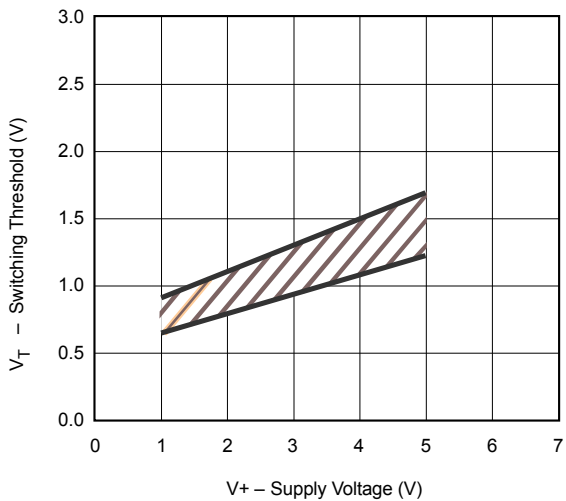

Switching Threshold vs. Supply Voltage

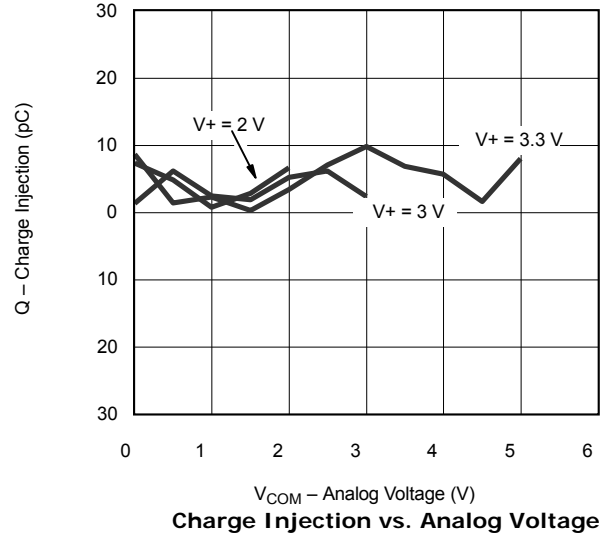

Charge Injection vs. Analog Voltage

Test Circuits

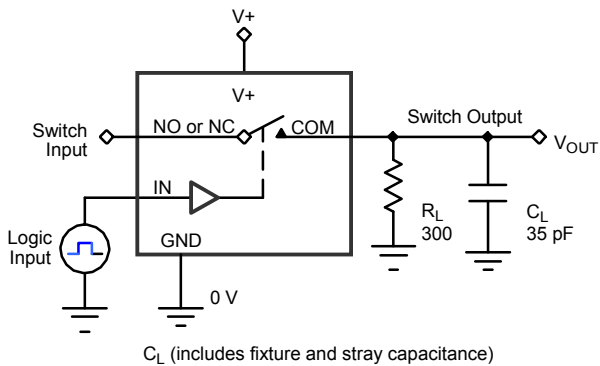

$$V_{OUT} = V_{COM} \left(\frac{R_L}{R_L + R_{ON}} \right)$$

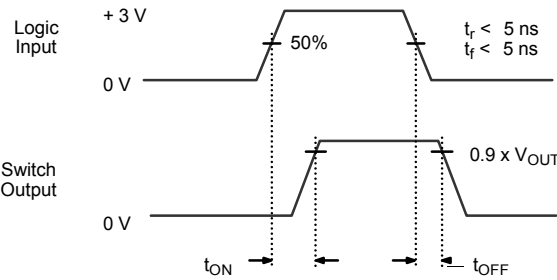

Logic "1" = Switch On
Logic input waveforms inverted for switches that have the opposite logic sense.

Figure 1. Switching Time

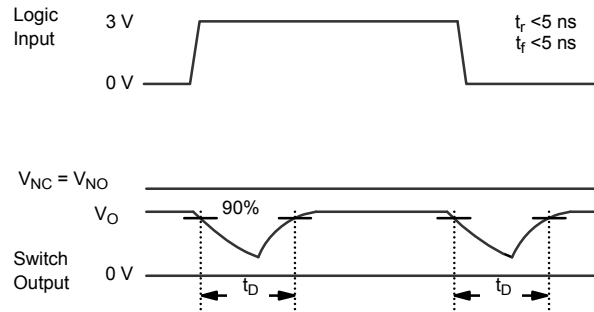
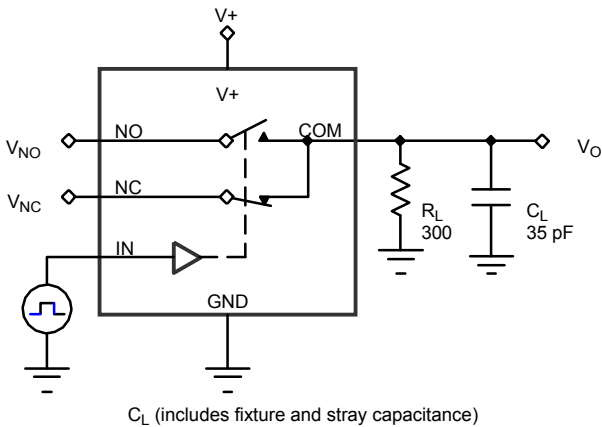
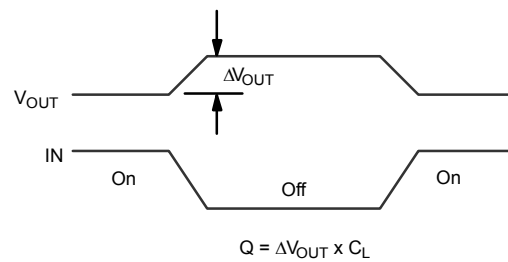
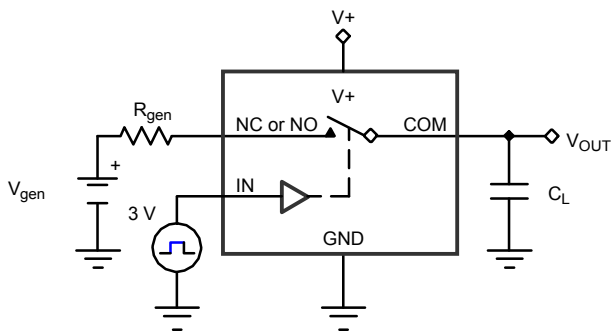

Figure 2. Break-Before-Make Interval



IN depends on switch configuration: input polarity determined by sense of switch.

Figure 3. Charge Injection

Test Circuits

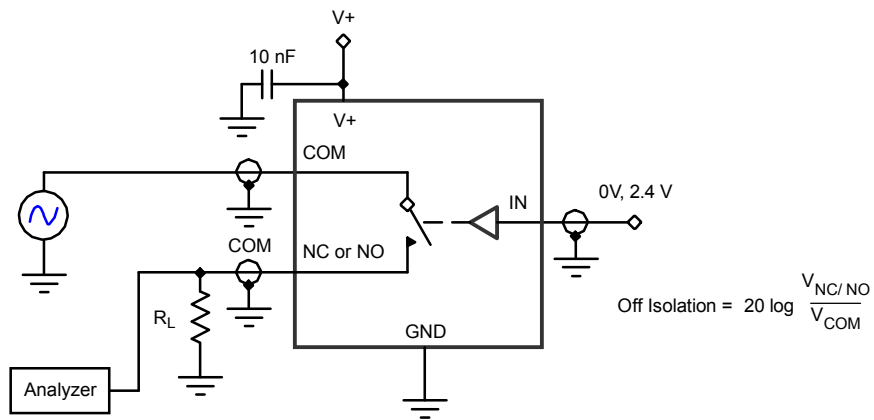

Figure 4. Off-Isolation

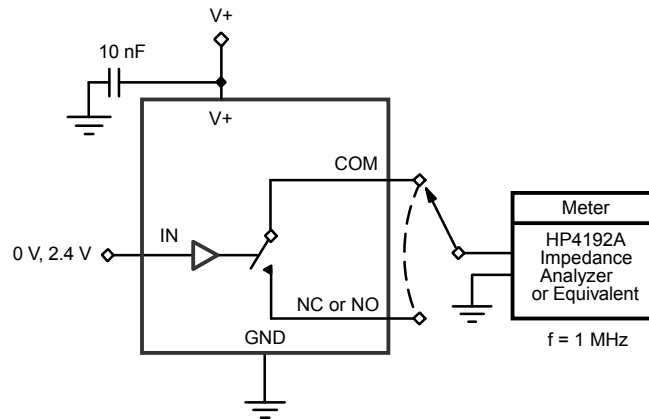
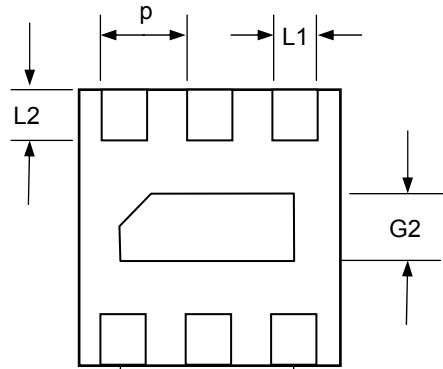
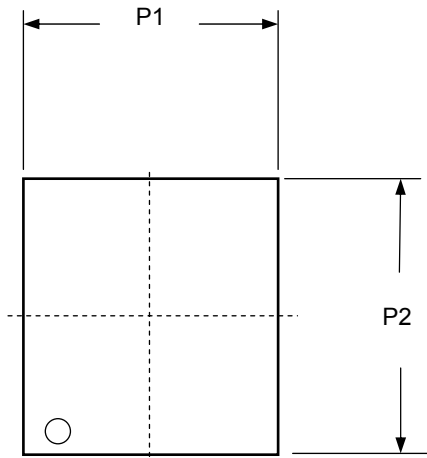
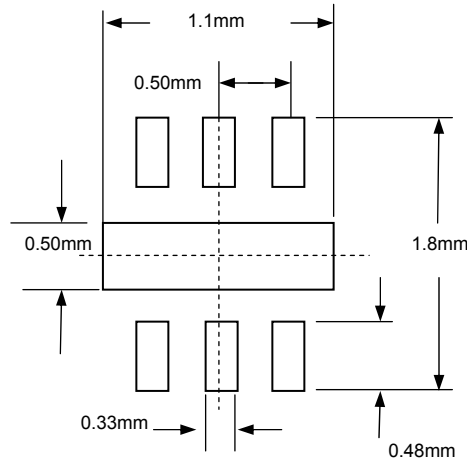
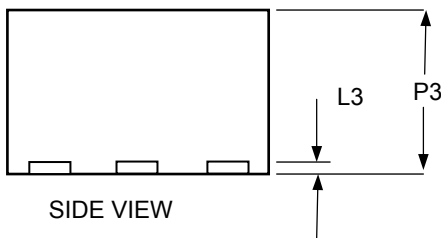

Figure 5. Channel Off/On Capacitance

Package Outline and Dimensions DFN-6



Dim	MILLIMETERS		INCHES	
	MIN	MAX	MIN	MAX
P1	1.5	1.7	0.060	0.066
P2	1.5	1.7	0.060	0.066
P3	0.45	0.65	0.018	0.026
L1	0.23	0.27	0.009	0.012
L2	0.20	0.30	0.008	0.012
L3	0.01	0.09	0.001	0.003
P	0.50	0.50	0.020	0.020
G1	0.90	1.10	0.035	0.043
G2	0.38	0.43	0.013	0.017



Tape and Reel Specifications (Dimensions in mm)

Reel Dia	A0	B0	K0	D	E	F	W	P0	P2	P	t-max
178 (7")	1.80±0.10	1.80±0.10	0.80±0.10	1.50±0.10	1.75±0.10	3.50±0.05	8.00±0.30	4.00±0.10	2.00±0.05	4.00±0.10	0.25

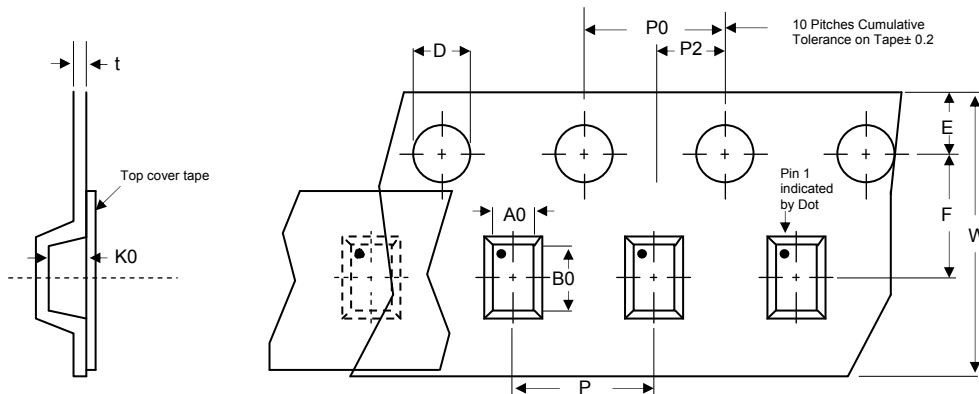

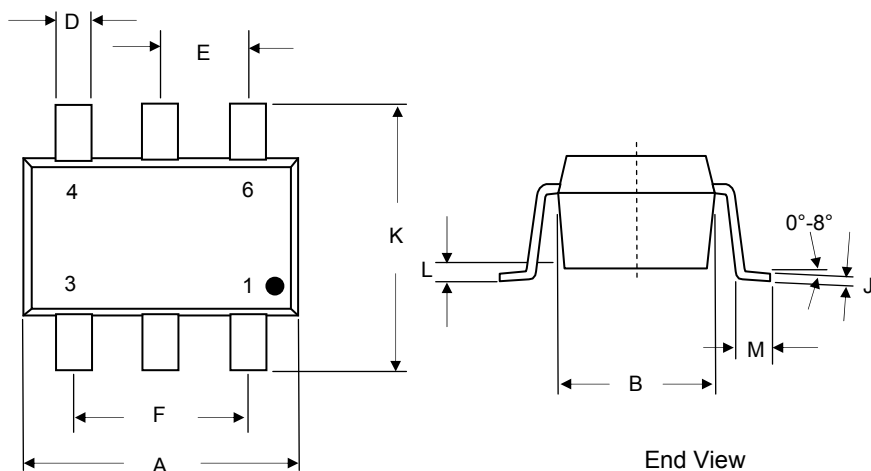
Package Outline and Dimensions SC70-6 Lead

Dim	MILLIMETERS		INCHES	
	MIN	MAX	MIN	MAX
A	1.90	2.15	0.074	0.084
B	1.15	1.35	0.045	0.055
C	0.80	1.00	0.031	0.040
D	0.15	0.30	0.006	0.012
E	0.65 BSC		0.0255 BSC	
F	1.30 BSC		0.0512 BSC	
G	0.80	1.10	0.031	0.043
J	0.08	0.25	0.003	0.010
K	2.00	2.20	0.078	0.086
L	0	0.10	0	0.004
M	0.26	0.46	0.010	0.018

LAND PATTERN		
1	0.50	0.020
2	1.30	0.051
3	0.65	0.026
4	1.72	0.068
5	0.60	0.024
6	1.11	0.044
7	2.33	0.092

Top View

End View

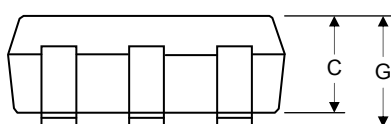

Side View

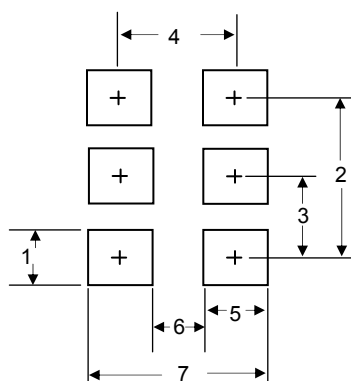

Recommended Land Pattern

Tape and Reel Specifications (Dimensions in mm)

Reel Dia	A0	B0	K0	D	E	F	W	P0	P2	P	t-max
178 (7")	2.25±0.10	2.34±0.10	1.22±0.10	1.50±0.10	1.75±0.10	3.50±0.05	8.00±0.30	4.00±0.10	2.00±0.05	4.00±0.10	0.25

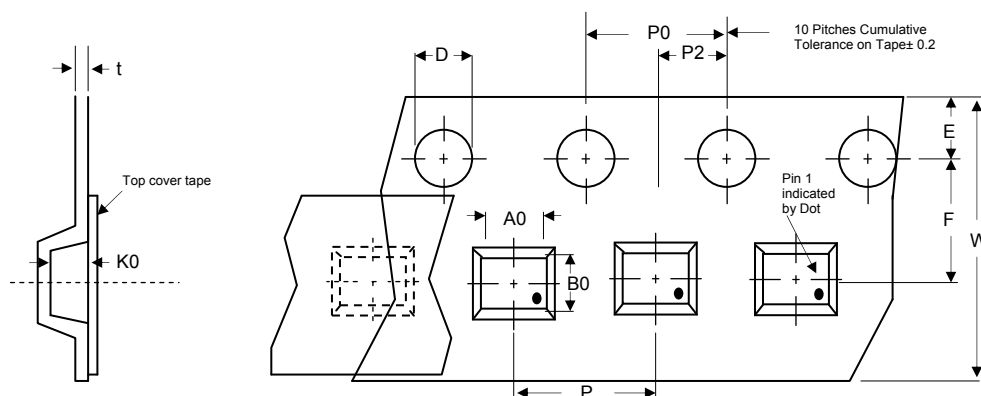
Life Support Policy

PROTEK ANALOG'S PRODUCTS ARE NOT AUTHORIZED FOR USE AS CRITICAL COMPONENTS IN LIFE SUPPORT DEVICES OR SYSTEMS WITHOUT THE EXPRESS WRITTEN APPROVAL OF THE PRESIDENT OF PROTEK DEVICES.