

### Features

- CMOS Technology for Bus and Analog Applications
- Low On-Resistance: 0.6Ω.
- V<sub>CC</sub> Range: 1.8V to 4.2V
- Rail-to-Rail Signal Range
- High Off Isolation: -75dB @ 100kHz
- Crosstalk Rejection: -90dB @ 100kHz
- Break-Before-Make Switching
- Extended Industrial Temperature Range: -40°C to 85°C
- LoPro® Packaging (Pb-free): 10-Lead Micro Package

### Applications

- Cell Phones
- PDAs
- MP3 players
- Portable Instrumentation
- Computer Peripherals
- Speaker Headset Switching
- Power Routing
- Relay Replacement
- Audio and Video Signal Routing
- PCMCIA Cards
- Modems

### Pin Descriptions

Pin No.	Name	Description
1,3	NO <sub>x</sub>	DATA Port (Normally Open)
4	GND	Ground
10,2	NC <sub>x</sub>	DATA Port (Normally Closed)
8,5	COM <sub>x</sub>	Common Port / DATA Port
9	V <sub>CC</sub>	Positive Power Supply
7,6	IN <sub>x</sub>	Logic Control

### Logic Function Table

Logic Input (IN <sub>x</sub> )	Function
0	NC <sub>x</sub> Connected to COM <sub>x</sub>
1	NO <sub>x</sub> Connected to COM <sub>x</sub>

### Description

ProTek Analog's PA2268 is a dual high-bandwidth, fast single-pole double throw (SPDT) CMOS switch. It can be used as an analog switch or as a low-delay bus switch. Specified over a operating power supply voltage, 1.8V to 4.2V, the PA2268 has an On-Resistance of 0.6Ω at +2.7V. Break-before-make switching prevents both switches being enabled simultaneously. This eliminates signal disruption during switching. The PA2268T includes termination resistors that improve noise immunity during overshoot excursions and off isolations or pop-up noise minimization

### Functional Block Diagrams

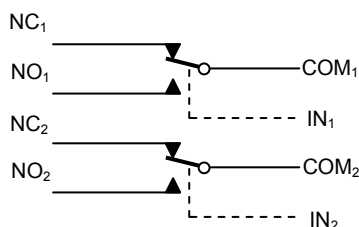

Fig. 1 PA2268

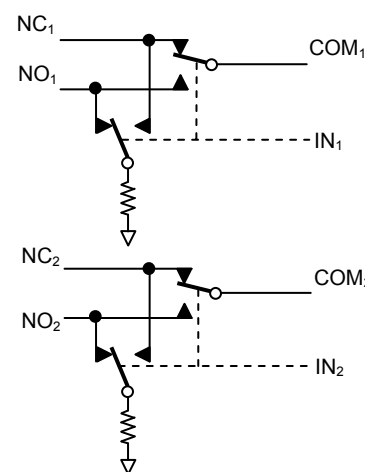
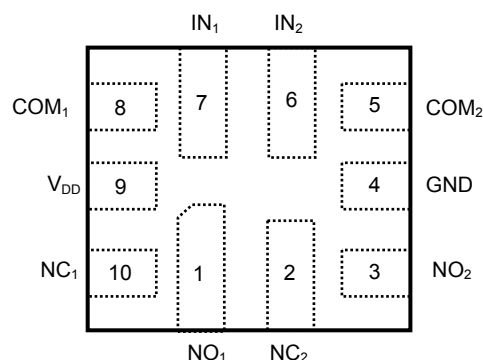

Fig.2 PA2268T (with termination resistors)

### Pin Configuration (Top View)



### Ordering Information

Temperature Range	Package	Part Number
-40 to 85 °C	10 Lead LoPro	PA2268-T7
-40 to 85 °C	10 Lead LoPro	PA2268T-T7

**Absolute Maximum Ratings<sup>(1)</sup>**

Supply Voltage VCC .....	4.5V
DC Switch Voltage (VS) <sup>(2)</sup> .....	V <sub>CC</sub> +0.5V
DC Input Voltage (VIN) <sup>(2)</sup> .....	4.5V
Continuous Current NO_NC_COM_ .....	±300mA Peak
Current NO_NC_COM_ .....	
(pulsed at 1ms 50% duty cycle) .....	±400mA Peak
Current NO_NC_COM_ .....	
(pulsed at 1ms 10% duty cycle) .....	±500mA
Storage Temperature Range (TSTG) ..	-65°C to +150°C
Junction Temperature under Bias (TJ).....	150°C
Junction Lead Temperature (TL) .....	
(Soldering, 10 seconds).....	260°C
Power Dissipation (PD) @ +85°C .....	250mW

**Recommended Operating Conditions<sup>(3)</sup>**

Supply Voltage Operating (V <sub>CC</sub> ) .....	1.8V to 4.2V
Control Input Voltage (V <sub>IN</sub> ).....	0V to V <sub>CC</sub> Switch Input
Voltage (V <sub>IN</sub> ).....	-0.3V to V <sub>CC</sub> Output Voltage
(V <sub>OUT</sub> ).....	0V to V <sub>CC</sub>
Operating Temperature (T <sub>A</sub> ).....	-40°C to +85°C
Input Rise and Fall Time (t <sub>r</sub> ,t <sub>f</sub> ) .....	
Control Input V <sub>CC</sub> = 2.3V - 3.6V.....	0ns/V to 10ns/V
Thermal Resistance (θ <sub>JA</sub> ).....	350°C/W
Lead Temperature (soldering 10s).....	+240°C
Bump Temperature (soldering notes)	
Infrared (15s).....	+220°C
Vapor Phase (60ns).....	+215°C

**Notes:**

1. "Absolute Maximum Ratings" may cause permanent damage to the device. This is a stress only rating and operation of the device at these or any other conditions beyond those indicated in the operational sections of this specification is not implied.
2. The input and output negative voltage ratings may be exceeded if the input and output diode current ratings are observed.
3. Control input must be held HIGH or LOW; it must not float.
4. Internal Resistance R<sub>TERM</sub> is guaranteed by design and not production tested.

**Capacitance**

Parameter	Symbol	Test Conditions	Min	Typ	Max	Unit
NC Off Capacitance	C <sub>NC(OFF)</sub>	f = 1MHz, See Test Circuit Figure7.		35		pF
NO Off Capacitance	C <sub>NO(OFF)</sub>	f = 1MHz, See Test Circuit Figure7.		35		
NC On Capacitance	C <sub>NC(ON)</sub>	f = 1MHz, See Test Circuit Figure8.		95		
NO On Capacitance	C <sub>NO(ON)</sub>	f = 1MHz, See Test Circuit Figure8.		95		

**DC Electrical Characteristics +3V Supply**
*(V<sub>CC</sub> = 2.7V to 3.3V, T<sub>A</sub> = -40°C to 85°C, unless otherwise noted. Typical values are at 3V and +25°C.)*

Parameter	Symbol	Test Conditions	Min	Typ	Max	Unit
<b>Analog Switch</b>						
Analog Signal Range	V <sub>NO</sub> , V <sub>NC</sub> , V <sub>COM</sub>		-0.3		V <sub>CC</sub>	V
NC On-Resistance	R <sub>ON(NC)</sub>	V <sub>CC</sub> = 2.7V, I <sub>COM</sub> = 100mA, V <sub>NC</sub> = 0 to V <sub>CC</sub>		0.4	0.6	Ω
NO On-Resistance	R <sub>ON(NO)</sub>	V <sub>CC</sub> = 2.7V, I <sub>COM</sub> = 100mA, V <sub>NO</sub> = 0 to V <sub>CC</sub>		0.4	0.6	
On-Resistance Match Between Channels	ΔR <sub>ON</sub>	V <sub>CC</sub> = 2.7V, I <sub>COM</sub> = 100mA, V <sub>NO</sub> or V <sub>NC</sub> = 1.5V		0.01	0.05	
NC On-Resistance Flatness	R <sub>ONF(NC)</sub>	V <sub>CC</sub> = 2.7V, I <sub>COM</sub> = 100mA, V <sub>NC</sub> = 0 to V <sub>CC</sub>			0.2	
NO On-Resistance Flatness	R <sub>ONF(NO)</sub>	V <sub>CC</sub> = 2.7V, I <sub>COM</sub> = 100mA, V <sub>NO</sub> = 0 to V <sub>CC</sub>			0.2	
Internal Termination Resistors	R <sub>TERM</sub>			200		Ω
NO or NC Off Leakage Current	I <sub>OFF(NO)</sub> or I <sub>OFF(NC)</sub>	V <sub>CC</sub> = 3.3V, I <sub>COM</sub> , V <sub>NO</sub> or V <sub>NC</sub> = 3.0V, 0.3V V <sub>COM</sub> = 0.3V, 3.0V	-20		20	nA
COM On Leakage Current	I <sub>COM(ON)</sub>	V <sub>CC</sub> = 3.3V, I <sub>COM</sub> , V <sub>NO</sub> or V <sub>NC</sub> = 3.0V, 0.3V V <sub>COM</sub> = 0.3V, 3.0V or Floating	-20		20	
<b>Digital I/O</b>						
Input Logic High	V <sub>IH</sub>		1.3			V
Input Logic Low	V <sub>IL</sub>				0.5	
Input Hysteresis	V <sub>H</sub>	V <sub>CC</sub> = 3.3V		300		mV
IN Input Leakage Current	I <sub>IN</sub>	V <sub>IN</sub> = 0 or V <sub>CC</sub>	-0.5		0.5	μA
Supply Current	I <sub>CC</sub>	V <sub>CC</sub> = 3.6V, V <sub>IN</sub> = 0 or V <sub>CC</sub>		0.9	1.2	nA

**Switch and AC Characteristics**

Parameter	Symbol	Test Conditions	Min	Typ	Max	Unit
Turn-On Time	t <sub>ON</sub>	V <sub>CC</sub> = 2.7V, V <sub>NO</sub> or V <sub>NC</sub> = 1.5V, R <sub>L</sub> = 50Ω, C <sub>L</sub> = 35pF. See Test Circuit Figure 1 & 2		15	25	nS
Turn-Off Time	t <sub>OFF</sub>	V <sub>CC</sub> = 2.7V, V <sub>NO</sub> or V <sub>NC</sub> = 1.5V, R <sub>L</sub> = 50Ω, C <sub>L</sub> = 35pF. See Test Circuit Figure 1 & 2		4	10	
Break-Before-Make Delay	t <sub>BBM</sub>	V <sub>CC</sub> = 2.7V, V <sub>NO</sub> or V <sub>NC</sub> = 1.5V, R <sub>L</sub> = 50Ω, C <sub>L</sub> = 35pF. See Test Circuit Figure 3			20	
Charge Injection	Q	COM = 0, R <sub>S</sub> = 0, C <sub>L</sub> = 1nF. V <sub>GEN</sub> = 0 See Test Circuit Figure 4		55		pC
Off-Isolation	Q <sub>IRR</sub>	C <sub>L</sub> = 5pF, R <sub>L</sub> = 50Ω, f = 100kHz, V <sub>COM</sub> = 1V <sub>RMS</sub> See Test Circuit Figure 5		-75		dB
Crosstalk	X <sub>TALK</sub>	C <sub>L</sub> = 5pF, R <sub>L</sub> = 50Ω, f = 100kHz, V <sub>COM</sub> = 1V <sub>RMS</sub> See Test Circuit Figure 6		-90		
3dB Bandwidth	f <sub>3dB</sub>	See Test Circuit Figure 9		100		MHz

**Typical Characteristics**

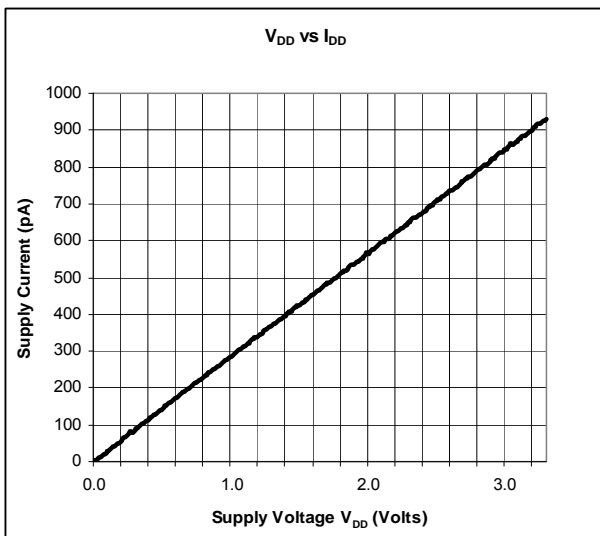
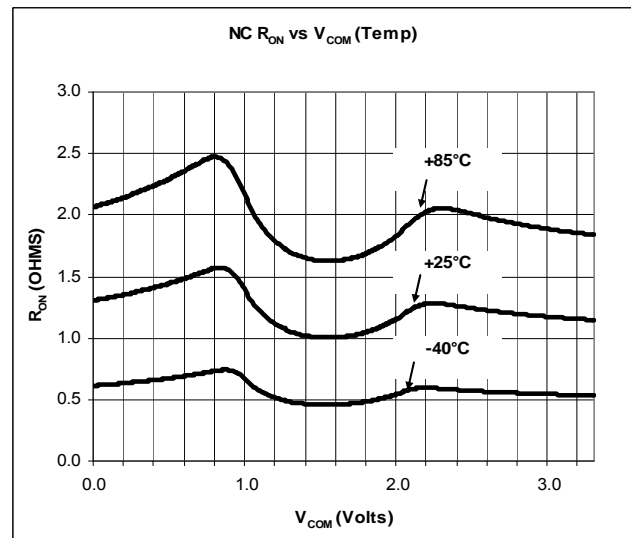
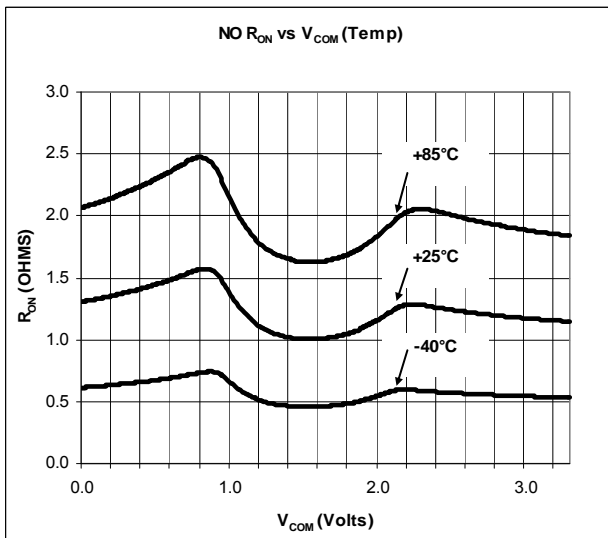
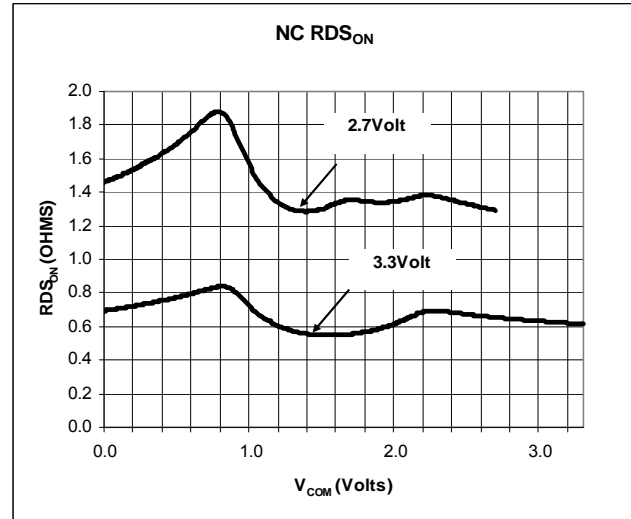
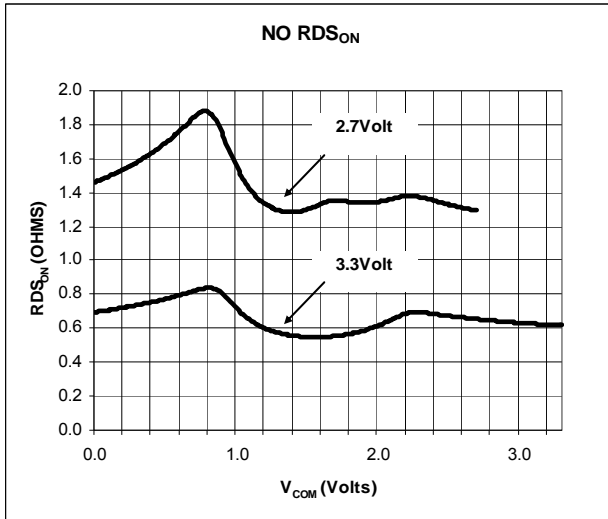

Note: Characteristics are guaranteed by design and are not production tested.

**Test Circuits and Timing Diagrams**

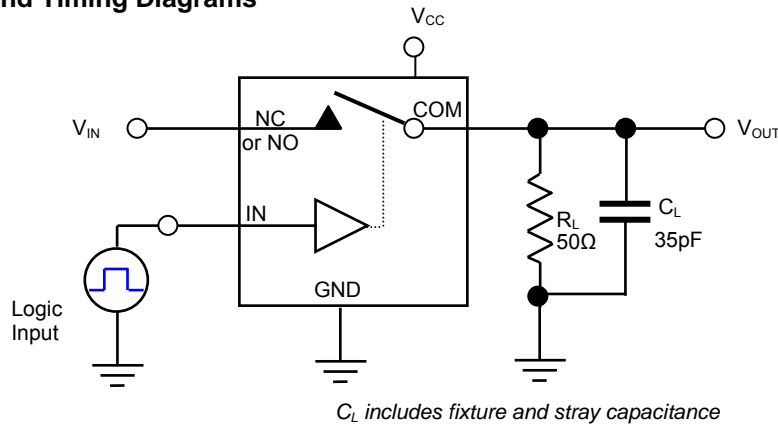

**Figure 1. AC Test Circuit**

**Note1.** Unused Input (NO or NC) must be grounded

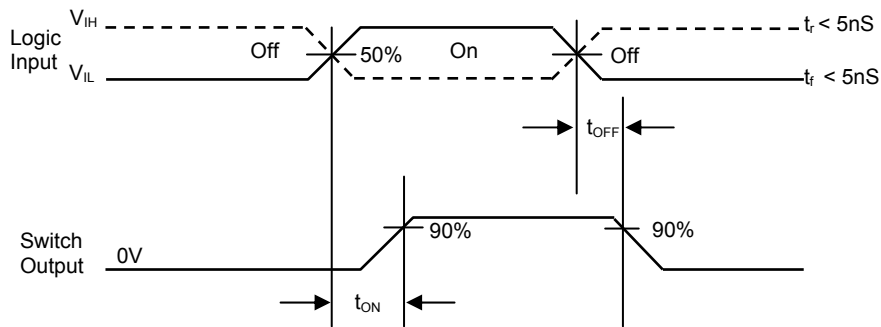

*Logic Input Waveforms inverted for Switches that have opposite logic*

**Figure2 AC Waveforms**

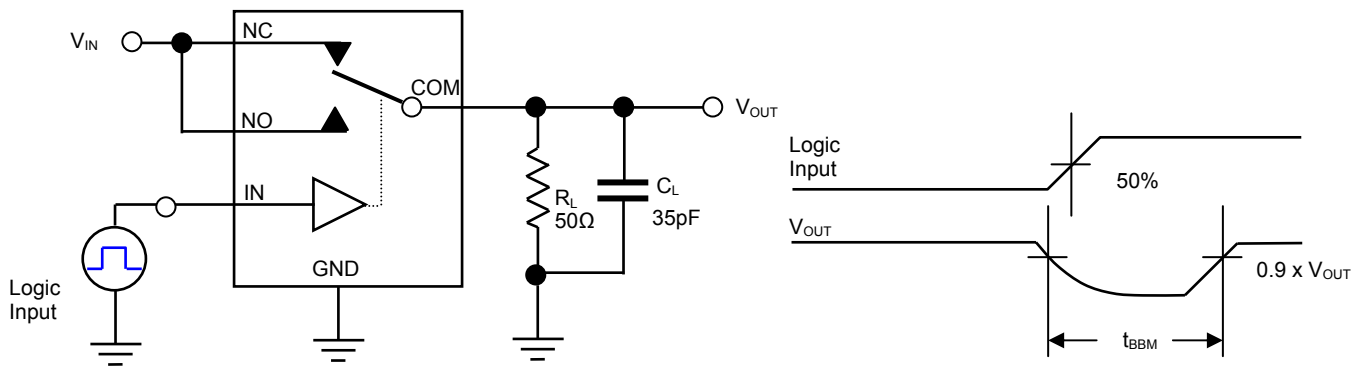

**Figure 3. Break Before Make Interval Timing**

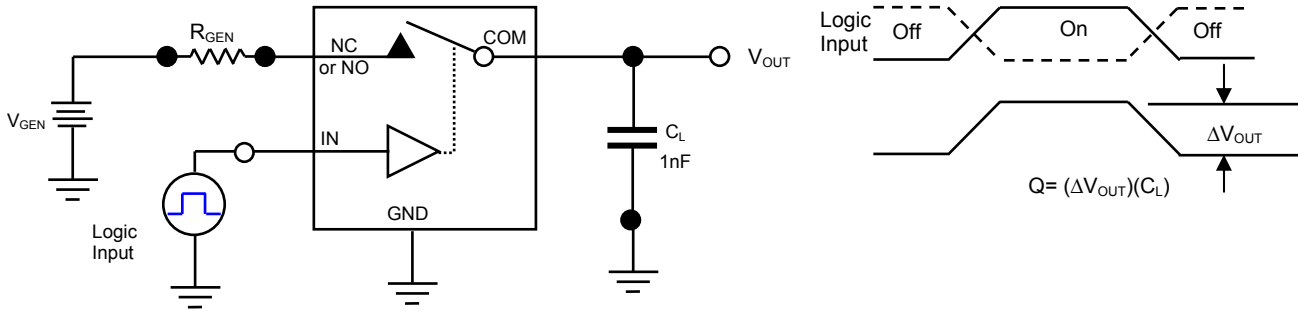

Figure 4. Charge Injection Test

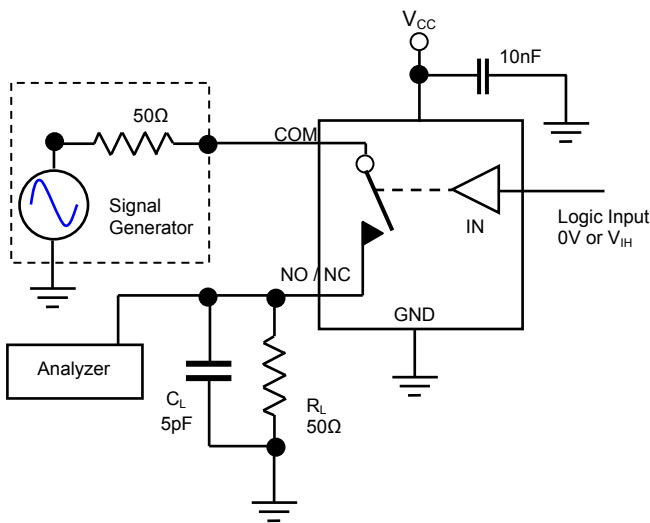

Figure 5. Off Isolation

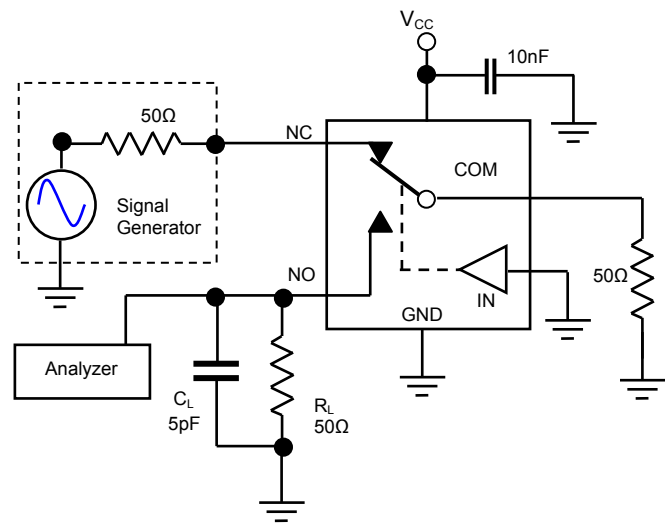

Figure 6. Crosstalk

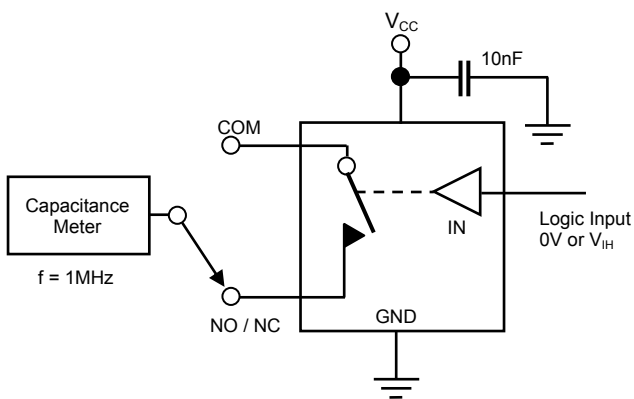

Figure 7. Channel Off Capacitance

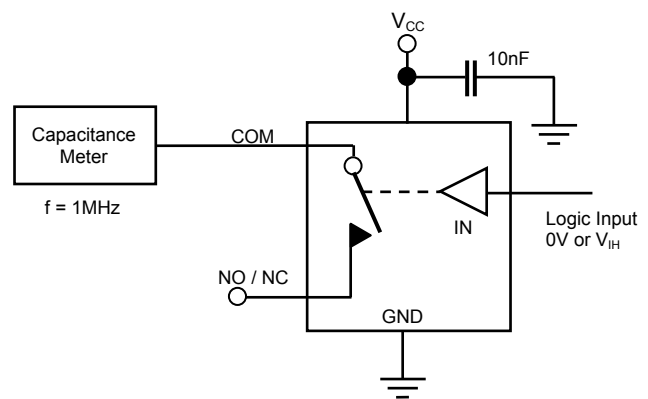
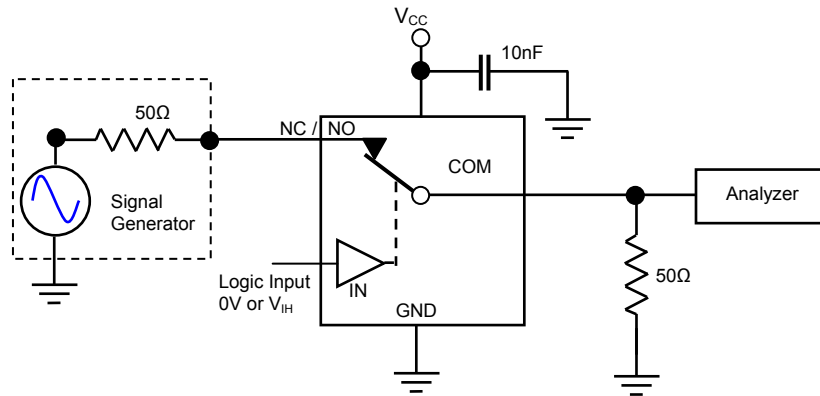
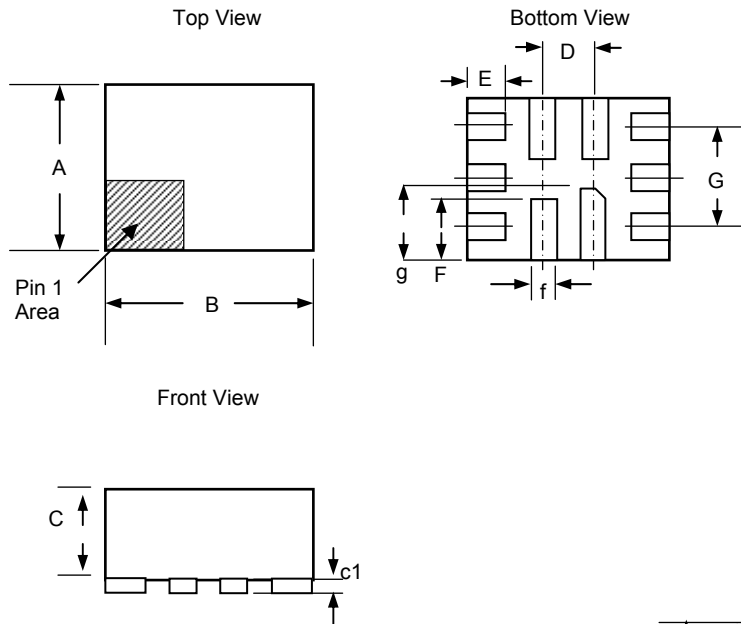

Figure 8. Channel On Capacitance

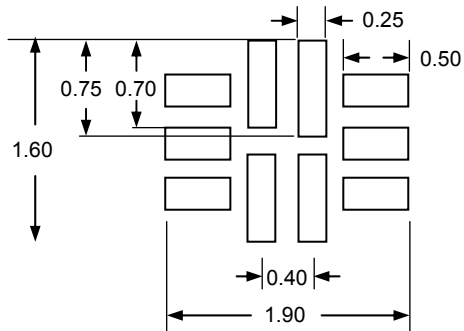

**Figure 9. Bandwidth**

**Package Layout and Dimensions**

DIM	MIN	TYP	Max
A	1.25	1.30	1.35
B	1.55	1.60	1.65
C	0.50	0.55	0.60
D	0.40		
E	0.29	0.30	0.31
F	0.49	0.50	0.51
G	0.80 REF		
c	0.00 - 0.05		
c1	0.10 REF		
f	0.15	0.20	0.25
g	0.59	0.60	0.61

Note: Package Dimensions in millimeters

**Recommended Land Pattern**

**Tape and Reel Specifications**

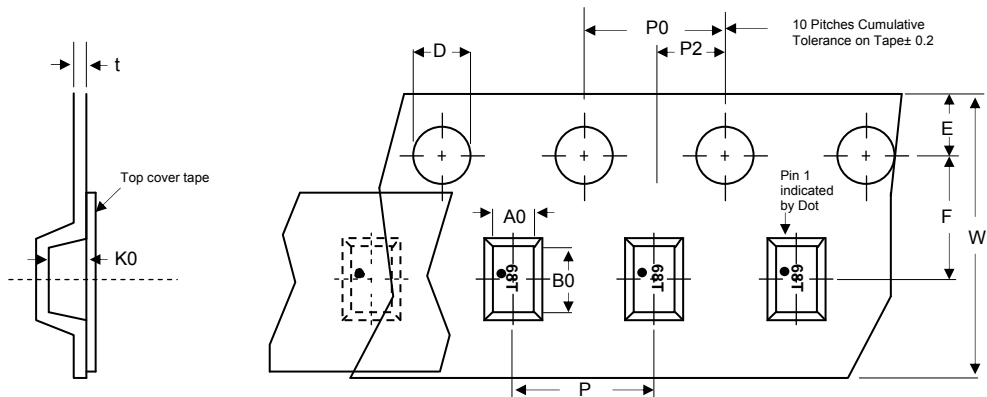
Reel Dia	A0	B0	K0	D	E	F	W	P0	P2	P	t-max
178 (7")	1.47±0.05	1.73±0.05	0.65±0.05	1.50±0.10	1.75±0.10	3.50±0.05	12.00±0.30	4.00±0.10	2.00±0.05	4.00±0.10	0.25



**Life Support Policy**

PROTEK ANALOG'S PRODUCTS ARE NOT AUTHORIZED FOR USE AS CRITICAL COMPONENTS IN LIFE SUPPORT DEVICES OR SYSTEMS WITHOUT THE EXPRESS WRITTEN APPROVAL OF THE PRESIDENT OF PROTEK DEVICES.