

FEATURES

DAC

- 24-bit, 8 kHz to 96 kHz sampling frequency
- 96 dB dynamic range, 96 dB signal to noise ratio, -83 dB THD+N
- 40 mW headphone amplifier, pop noise free, capless option
- Stereo enhancement
- Bass and Treble adjustments
- Various analog output mixing and gains

Low Power

- 1.8V to 3.3V operation
- 7 mW playback

System

- I²C or SPI uC interface
- 256Fs, 384Fs, USB 12 MHz or 24 MHz
- Master or slave serial port
- I²S, Left Justified, DSP/PCM Mode
- Fractional PLL for wide range of system clocks

APPLICATIONS

- GPS
- Bluetooth
- MP3, MP4, PMP
- Cell phone
- Digital camera, camcorder
- Portable audio devices

GENERAL DESCRIPTION

PA5155 is a high performance, low power and low cost audio DAC. It consists of 2-ch DAC, headphone amplifier, digital sound effects, and analog mixing and gain functions.

The device uses advanced multi-bit delta-sigma modulation technique to convert data between digital and analog.

The multi-bit delta-sigma modulators make the device with low sensitivity to clock jitter and low out of band noise.

BLOCK DIAGRAM

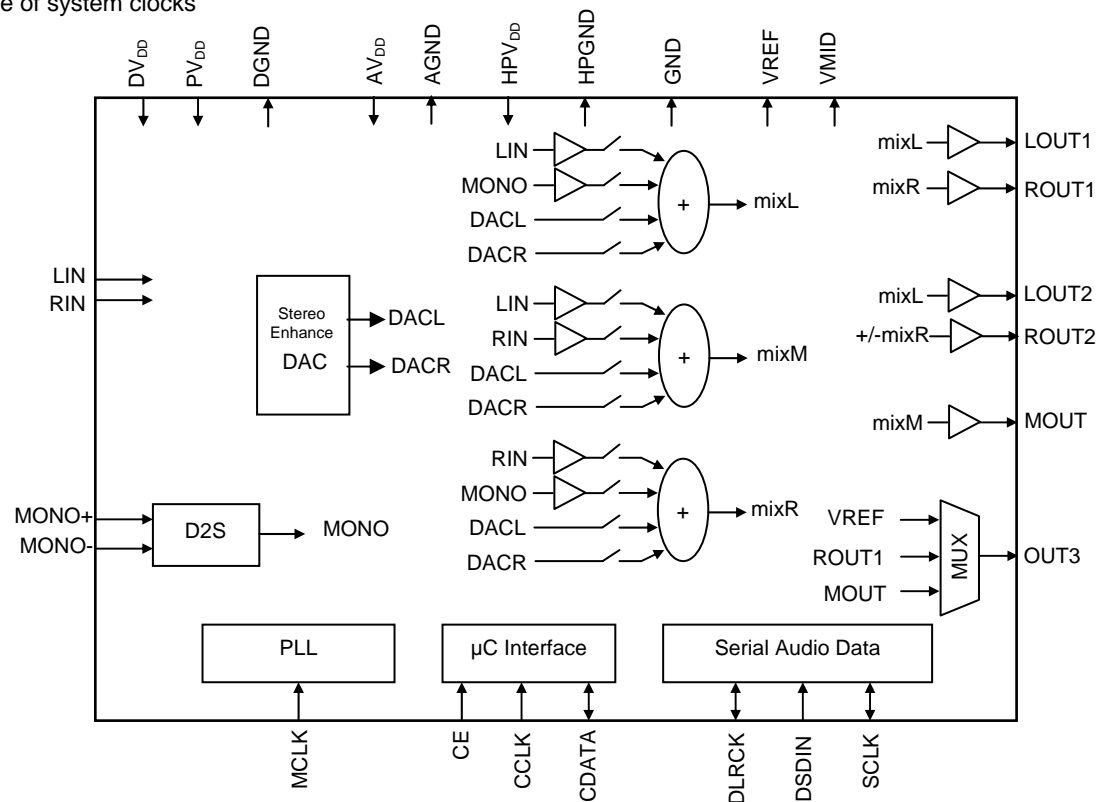

ORDERING INFORMATION

Temperature Range	Package	Part Number
-40 to 85 °C	QFN-28	PA5155-T7

ABSOLUTE MAXIMUM RATINGS

 Supply Voltage MIN-0.3V MAX +5.0V
 Input Voltage MIN GND-0.3V MAX $V_{DD}+0.3V$
 Operating Temperature.....MIN -40°C MAX +85°C
 Storage Temperature.....MIN -65°C MAX +150°C

RECOMMENDED OPERATING CONDITIONS

 Analog Supply Voltage MIN 1.7V MAX 3.6V
 Digital Supply Voltage MIN 1.5V MAX 3.6V

Note: Continuous operation at or beyond these conditions may permanently damage the device.

DAC ANALOG AND FILTER CHARACTERISTICS AND SPECIFICATIONS

Test conditions are as the following unless otherwise specify:

AVDD=+3.3V, DVDD=+1.8V, AGND=0V, DGND=0V, Ambient temperature=+25°C, Fs=48 KHz, 96 KHz or 192 KHz, MCLK/LRCK=256.

PARAMETER	MIN	TYP	MAX	UNIT
DAC Performance				
Dynamic Range (Note 1)	83	96	98	dB
THD+N	-85	-83	-75	dB
Channel Separation (1KHz)	80	85	90	dB
Signal to Noise ratio	83	96	98	dB
Inter-channel Gain Mismatch		0.05		dB
Filter Frequency Response – Single Speed				
Passband	0		0.4535	Fs
Stopband	0.5465			Fs
Passband Ripple			±0.05	dB
Stopband Attenuation	40			dB
Filter Frequency Response – Double Speed				
Passband	0		0.4167	Fs
Stopband	0.5833			Fs
Passband Ripple			±0.005	dB
Stopband Attenuation	40			dB
De-emphasis Error at 1 KHz (Single Speed Mode Only)				
Fs = 32KHz Fs = 44.1KHz Fs = 48KHz			0.002 0.013 0.0009	dB
Analog Output				
Full Scale Output Level		AVDD/3.3		Vrms

Note

1. The value is measured used A-weighted filter.

POWER CONSUMPTION CHARACTERISTICS

PARAMETER	MIN	TYP	MAX	UNIT
Normal Operation Mode				
DVDD=1.8V, AVDD=1.8V: Play back		7		mW
DVDD=3.3V, AVDD=3.3V: Play back		31		
Power Down Mode				
DVDD=1.8V, AVDD=1.8V		0.3		mW
DVDD=3.3V, AVDD=3.3V		1.9		

SERIAL AUDIO PORT SWITCHING SPECIFICATIONS

PARAMETER	Symbol	MIN	MAX	UNIT
MCLK frequency			51.2	MHz
MCLK duty cycle		40	60	%
LRCK frequency			200	KHz
LRCK duty cycle		40	60	%
SCLK frequency			26	MHz
SCLK pulse width low	T_{SCLKL}	15		ns
SCLK Pulse width high	T_{SCLKH}	15		ns
SCLK falling to LRCK edge	T_{SLR}	-10	10	ns
SDIN valid to SCLK rising setup time	T_{SDIS}	10		ns
SCLK rising to SDIN hold time	T_{SDIH}	10		ns

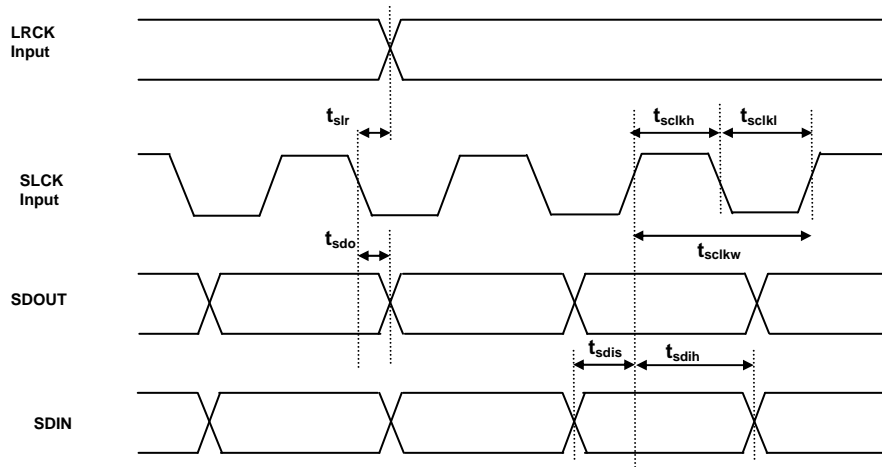

Serial Audio Port Timing

SERIAL CONTROL PORT SWITCHING SPECIFICATIONS

PARAMETER	Symbol	MIN	MAX	UNIT
SPI Mode				
SPI_CLK clock frequency			10	MHz
SPI_CLK edge to SPI_CS _n falling	T_{SPICS}	5		ns
SPI_CS _n High Time Between transmissions	T_{SPISH}	500		ns
SPI_CS _n falling to SPI_CLK edge	T_{SPISC}	10		ns
SPI_CLK low time	T_{SPICL}	45		ns
SPI_CLK high time	T_{SPICH}	45		ns
SPI_DIN to SPI_CLK rising setup time	T_{SPIDS}	10		ns
SPI_CLK rising to DATA hold time	T_{SPIDH}	15		ns
2-wire Mode				
SCL Clock Frequency	F_{SCL}		100	KHz
Bus Free Time Between Transmissions	T_{TWID}	4.7		us
Start Condition Hold Time	T_{TWSTH}	4.0		us
Clock Low time	T_{TWCL}	4.0		us



Clock High Time	T_{TWCH}	4.0		us
Setup Time for Repeated Start Condition	T_{TWSTS}	4.7		us
SDA Hold Time from SCL Falling	T_{TWDH}	0.1		us
SDA Setup time to SCL Rising	T_{TWDS}	100		ns
Rise Time of SCL	T_{TWR}		25	us
Fall Time SCL	T_{TWF}		25	ns

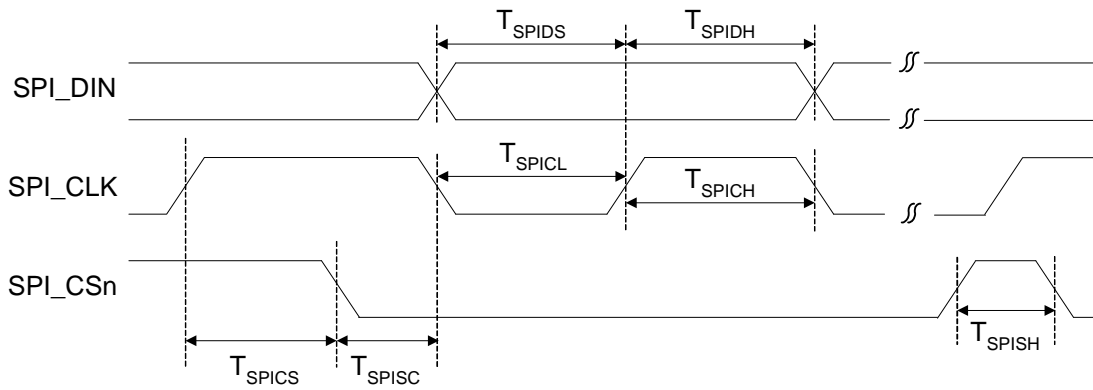

Serial Control Port SPI Timing

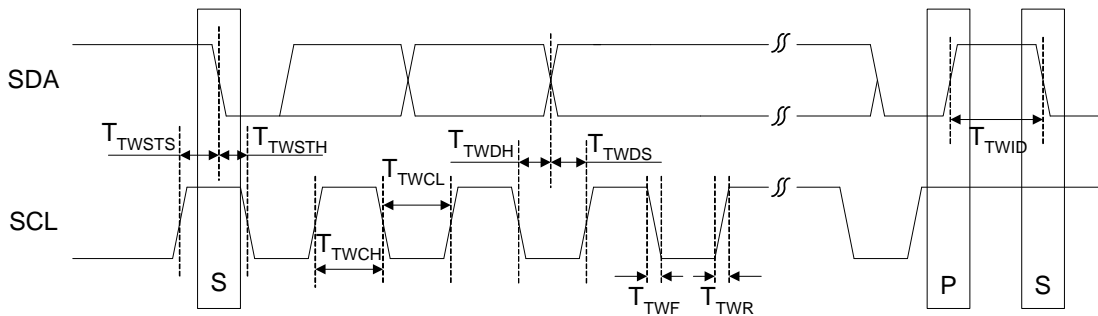

Serial Control Port 2-wire Timing

TYPICAL APPLICATION CIRCUIT

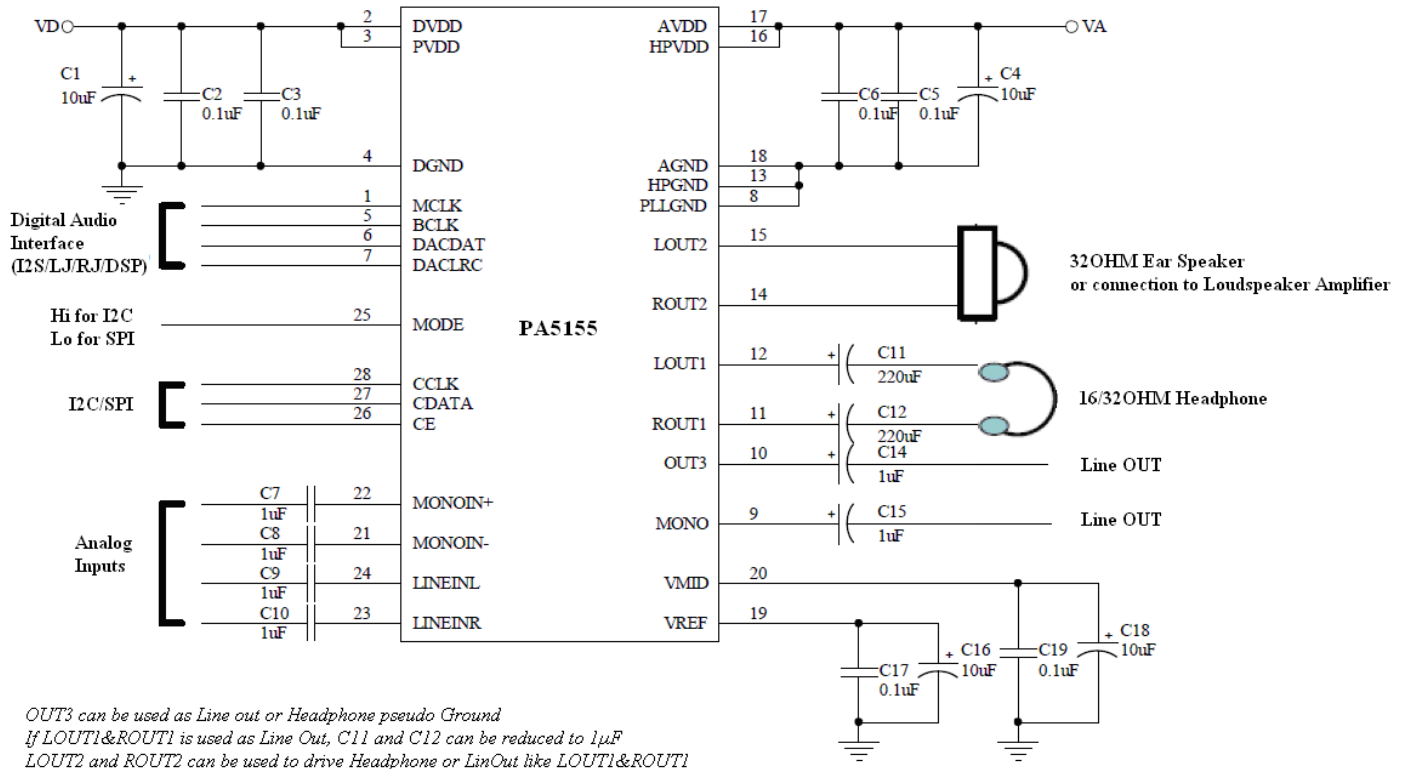

CLOCK MODES AND SAMPLING FREQUENCIES

According to the input serial audio data sampling frequency, the device can work in two speed modes: single speed or double speed. The ranges of the sampling frequency in these two modes are listed in Table 1. The device can work either in master clock mode or slave clock mode.

In slave mode, LRCK and SCLK are supplied externally. LRCK and SCLK must be synchronously derived from the system clock with specific rates. The device can auto detect MCLK/LRCK ratio according to Table 1. The device only supports the MCLK/LRCK ratios listed in Table 1. The LRCK/SCLK ratio is normally 64.

Table 1 Slave Mode Sampling Frequencies and MCLK/LRCK Ratio

Speed Mode	Sampling Frequency	MCLK/LRCK Ratio
Single Speed	8kHz – 50kHz	256, 384, 512, 768, 1024
Double Speed	50kHz – 100kHz	128, 192, 256, 384, 512

In master mode, LRCK and SCLK are derived internally from MCLK. The available MCLK/LRCK ratios and SCLK/LRCK ratios are listed in Table 2.

Table 2 Master Mode Sampling Frequencies and MCLK/LRCK Ratio

MCLK CLKDIV2=0	MCLK CLKDIV2=1	DAC Sample Rate (DLRCK)	DACFsRatio [4:0]	SCLK Ratio
Normal Mode				
12.288 MHz	24.576MHz	8 kHz (MCLK/1536)	01010	MCLK/6
		48 kHz (MCLK/256)	00010	MCLK/4
		12 kHz (MCLK/1024)	00111	MCLK/4
		16 kHz (MCLK/768)	00110	MCLK/6
		24 kHz (MCLK/512)	00100	MCLK/4
		32 kHz (MCLK/384)	00011	MCLK/6

		8 kHz (MCLK/1536)	01010	MCLK/4
		48 kHz (MCLK/256)	00010	MCLK/4
		96 kHz (MCLK/128)	00000	MCLK/2
11.2896 MHz	22.5792MHz	8.0182 kHz (MCLK/1408)	01001	MCLK/4
		44.1 kHz (MCLK/256)	00010	MCLK/4
		11.025 kHz (MCLK/1024)	00111	MCLK/4
		22.05 kHz (MCLK/512)	00100	MCLK/4
		8.0182 kHz (MCLK/1408)	01001	MCLK/4
		44.1 kHz (MCLK/256)	00010	MCLK/4
		88.2 kHz (MCLK/128)	00000	MCLK/2
		18.432 MHz	36.864MHz	8 kHz (MCLK/2304)
48 kHz (MCLK/384)	00011			MCLK/6
12 kHz (MCLK/1536)	01010			MCLK/6
16 kHz (MCLK/1152)	01000			MCLK/6
24 kHz (MCLK/768)	00110			MCLK/6
32 kHz (MCLK/576)	00101			MCLK/6
8 kHz (MCLK/2304)	01100			MCLK/6
48 kHz (MCLK/384)	00011			MCLK/6
16.9344 MHz	33.8688MHz	96 kHz (MCLK/192)	00001	MCLK/3
		8.0182 kHz (MCLK/2112)	01011	MCLK/6
		44.1 kHz (MCLK/384)	00011	MCLK/6
		11.025 kHz (MCLK/1536)	01010	MCLK/6
		22.05 kHz (MCLK/768)	00110	MCLK/6
		8.0182 kHz (MCLK/2112)	01011	MCLK/6
		44.1 kHz (MCLK/384)	00011	MCLK/6
		88.2 kHz (MCLK/192)	00001	MCLK/3
USB Mode				
12 MHz	24MHz	8 kHz (MCLK/1500)	11011	MCLK
		48 kHz (MCLK/250)	10010	MCLK
		8.0214 kHz (MCLK/1496)	11010	MCLK
		44.118 kHz (MCLK/272)	10011	MCLK
		11.0259 kHz (MCLK/1088)	11001	MCLK
		12 kHz (MCLK/1000)	11000	MCLK
		16 kHz (MCLK/750)	10111	MCLK
		22.0588 kHz (MCLK/544)	10110	MCLK
		24 kHz (MCLK/500)	10101	MCLK
		32 kHz (MCLK/375)	10100*	MCLK
		8.0214 kHz (MCLK/1496)	11010	MCLK
		44.118 kHz (MCLK/272)	10011	MCLK
		8 kHz (MCLK/1500)	11011	MCLK
		48 kHz (MCLK/250)	10010	MCLK
		88.235 kHz (MCLK/136)	10001	MCLK
		96 kHz (MCLK/125)	10000	MCLK

PA5155 has a high performance fractional-N PLL. PLL can be used for non-standard MCLK to generate standard internal master clock, for example 12.288 MHz for 48 kHz sampling frequency or 11.2896 MHz for 44.1 kHz sampling frequency. By default, PLL is in power down and reset, and the internal master clock uses MCLK clock from pin directly. The following table shows the PLL setting (MCLKDIV2, PLL_N, PLL_K and PLLOUT_DIV2) for typical non-standard MCLK to generate standard internal master clock.

MCLK (MHz)	Internal Master Clock (MHz)	F2 (MHz)	MCLKDIV2	PLLOUT_DIV2	R	N	f (*0.6574)	PLL_N	PLL_K
11.91	11.2896	90.3168	0	1	7.5833	7	0.3834	7	188A3F
11.91	12.288	98.304	0	1	8.2539	8	0.1669	8	AAE8C
12	11.2896	90.3168	0	1	7.5264	7	0.3460	7	16256C
12	12.288	98.304	0	1	8.192	8	0.1262	8	813E0
13	11.2896	90.3168	0	1	6.9474	6	0.6228	6	27DBAB
13	12.288	98.304	0	1	7.5618	7	0.3693	7	17A2B0
14.4	11.2896	90.3168	0	1	6.272	6	0.1788	6	B717D

14.4	12.288	98.304	0	1	6.8267	6	0.5434	6	22C7B5
19.2	11.2896	90.3168	1	1	9.408	9	0.2682	9	112A3C
19.2	12.288	98.304	1	1	10.24	10	0.1578	A	A18D8
19.68	11.2896	90.3168	1	1	9.1785	9	0.1173	9	7827A
19.68	12.288	98.304	1	1	9.9902	9	0.6509	9	29A8A2
19.8	11.2896	90.3168	1	1	9.1229	9	0.0808	9	52BA7
19.8	12.288	98.304	1	1	9.9297	9	0.6111	9	271D0A
24	11.2896	90.3168	1	1	7.5264	7	0.3460	7	16.256C
24	12.288	98.304	1	1	8.192	8	0.1262	8	813E0
26	11.2896	90.3168	1	1	6.9474	6	0.6228	6	27DBAB
26	12.288	98.304	1	1	7.5618	7	0.3693	7	17A2B0
27	11.2896	90.3168	1	1	6.6901	6	0.4536	6	1D0880
27	12.288	98.304	1	1	7.2818	7	0.1852	7	BDB09

MICRO-CONTROLLER CONFIGURATION INTERFACE

The device supports standard SPI and 2-wire micro-controller configuration interface. External micro-controller can completely configure the device through writing to internal configuration registers. Please see section 8 for the details of configuration register definition.

The identical device pins are used to configure either SPI or 2-wire interface. In SPI mode, pin CE, CCLK and CDATA function as SPI_CS_n, SPI_CLK and SPI_DIN. In 2-wire mode, pin CE, CCLK and CDATA function as AD₀, SCL and SDA. To select SPI mode, apply high to low transition signal to CE pin. Otherwise the device will operate in 2-wire interface mode.

SPI

PA5155 has a SPI (Serial Peripheral Interface) compliant synchronous serial slave controller inside the chip. It provides the ability to allow the external master SPI controller to access the internal registers, and thus control the operations of chip.

All lines on the SPI bus are unidirectional: The SPI_CLK is generated by the master controller and is primarily used to synchronize data transfer, the SPI_DIN line carries data from the master to the slave; SPI_CS_n is generated by the master to select PA5155.

The timing diagram of this interface is given in Figure 1. The high to low transition at SPI_CS_n pin indicates the SPI interface selected. Each write procedure contains 3 words, i.e. Chip Address plus R/W bit, internal register address and internal register data. Every word length is fixed at 8 bits. The input SPI_DIN data are sampled at the rising edge of SPI_CLK clock. The MSB bit in each word is transferred firstly. The transfer rate can be up to 10Mbps.

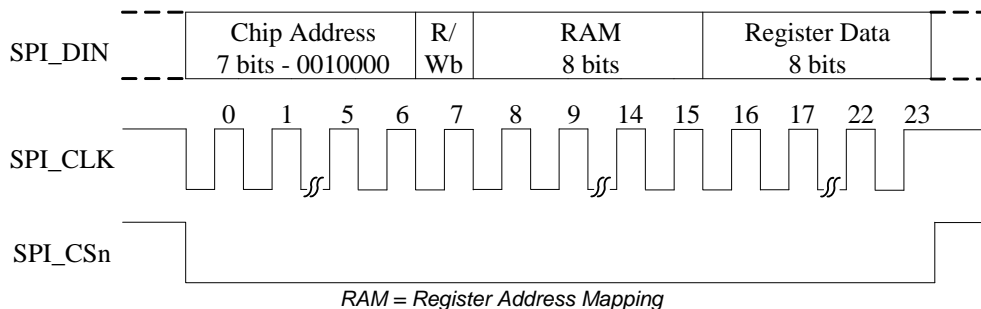

Figure 1 SPI Configuration Interface Timing Diagram

2-WIRE

2-wire interface is a bi-directional serial bus that uses a serial data line (SDA) and a serial clock line (SCL) for data transfer. The timing diagram for data transfer of this interface is given in Figure 2. Data are transmitted synchronously to SCL clock on the SDA line on a byte-by-byte basis. Each bit in a byte is sampled during SCL high with MSB bit being transmitted firstly. Each transferred byte is followed by an acknowledge bit from receiver to pull the SDA low. The transfer rate of this interface can be up to 100k bps.



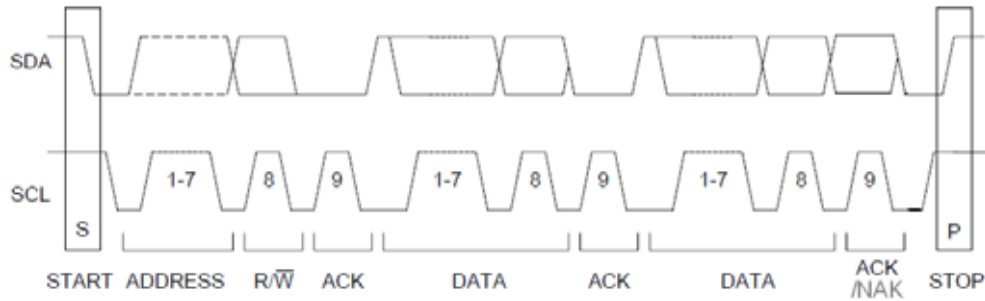

Figure 2 Complete Data Transfer for 2-wire Interface

A master controller initiates the transmission by sending a “start” signal, which is defined as a high-to-low transition at SDA while SCL is high. The first byte transferred is the slave address. It is a seven-bit chip address followed by a RW bit. The chip address must be 001000x, where x equals AD0 (pin CE). The RW bit indicates the slave data transfer direction. Once an acknowledge bit is received, the data transfer starts to proceed on a byte-by-byte basis in the direction specified by the RW bit. The master can terminate the communication by generating a “stop” signal, which is defined as a low-to-high transition at SDA while SCL is high.

In 2-wire interface mode, the registers can be written and read. The formats of “write” and “read” instructions are shown in Table 3 and Table 4. Please note that, to read data from a register, you must set R/W bit to 0 to access the register address and then set R/W to 1 to read data from the register. There are no acknowledge bit after data to be written or read, this is the only difference from the I²C protocol.

Table 3 Write Data to Register in 2-wire Interface Mode

Chip Address	R/W	Register Address	Data to be written			
001000	AD0	0	ACK	RAM	ACK	DATA

Table 4 Read Data from Register in 2-wire Interface Mode

Chip Address	R/W	Register Address				
001000	AD0	0	ACK	RAM		
Chip Address	R/W	Data to be read				
001000	AD0	1	ACK	DATA		

CONFIGURATION REGISTER DEFINITION

SPI and 2-wire configuration interface share the same registers because there is only one interface active at any time. There are total of 53 user programmable 8-bit registers in this device. These registers control the operations of DAC. External master controller can access these registers by using the slave address specified in RAM (Register Address Map) register as shown in the Table 5.

Table 5 Bit Content of Register Address Map

Adr	Name	Bit7	Bit6	Bit5	Bit4	Bit3	Bit2	Bit1	Bit0	default
0	LOUT1 Volume	LP_OUT1	PDN_LOUT1	LOUT1VOL						40
1	ROUT1 Volume		PDN_ROUT1	ROUT1VOL						40
2	LOUT2 Volume	LP_OUT2	PDN_LOUT2	LOUT2VOL						40
3	ROUT2 Volume		PDN_ROUT2	ROUT2VOL						40
4	MOUT Volume	LP_MOUT	PDN_MOUT	MOUTVOL						40
5	OUT Control 1	LP_OUT3	PDN_OUT3	OUT3SW		LP_ROUT2INV	ROUT2INV			40
6	OUT Control 2							L2R2BOTH	L1R1BOTH	00
7	Left Mixer	LI2LOMU	LI2LOVOL			MI2LOMU	MI2LOVOL			FF
8	Right Mixer	MI2ROMU	MI2ROVOL			RI2ROMU	RI2ROVOL			FF
9	Mono Mixer	LI2MOMU	LI2MOVOL			RI2MOMU	RI2MOVOL			FF
A	DAC to Mixer	PDN_MONODIFF	DMEN	LD2MOMU	RD2MOMU	LD2LOMU	RD2LOMU	LD2ROMU	RD2ROMU	BF
B	Mixer LP mode					LP_MONODIFF	LP_MMX	LP_LMIX	LP_RMIX	00
C	DAC Setting	Left DAC Volume	DACLVOL							C0
D		Right DAC Volume	DACRVOL							C0
E	DAC Control	LP_DACL	PDN_DACL	LP_DACR	PDN_DACR		DACLMMU		DACRMU	55
F	DAC Control	AUTOMUTE	CLICKFREE	VPPSCALE		DACLRBOTH	DACSOFTRAMP	DACRAMPRATE		C4
10	DAC Control			DACINVL	DACINVR	DACTOEN	DACDAT			08
11	DAC Control			DACZEROL	DACZEROR	DACMONO	DACSE			00
12	Shelving1_A	SHV1_A[29:24]								1F
13		SHV1_A[23:16]								F7
14		SHV1_A[15:8]								FD
15		SHV1_A[7:0]								FF
16	Shelving1_B	SHV1_B[29:24]								1F
17		SHV1_B[23:16]								F7
18		SHV1_B[15:8]								FD
19		SHV1_B[7:0]								FF
1A	Shelving2_A	SHV2_A[29:24]								1F
1B		SHV2_A[23:16]								F7
1C		SHV2_A[15:8]								FD
1D		SHV2_A[7:0]								FF
1E	Shelving2_B	SHV2_B[29:24]								1F

1F			SHV2_B[23:16]							F7		
20			SHV2_B[15:8]							FD		
21			SHV2_B[7:0]							FF		
22					SHV3_A[29:24]					1F		
23		Shelving3_A	SHV3_A[23:16]							F7		
24			SHV3_A[15:8]							FD		
25			SHV3_A[7:0]							FF		
26					SHV3_B[29:24]					1F		
27		Shelving3_B	SHV3_B[23:16]							F7		
28			SHV3_B[15:8]							FD		
29			SHV3_B[7:0]							FF		
2A	Digital Audio I/F Setting	Digital Interface	DACFORMAT		DACLRSWP		DACLRP	DACWL			00	
2B		Digital Interface				MCLKDIV2		SCLKINV	FSMODE	DACMSC	01	
2C		Sample Rate						DACSR			06	
2D		SCLK Divider						SCLKDIV			00	
2E	Reference Setting	Reset	RST_CP								00	
2F		Power Down					PDN_ANA	PDN_DIG	PDN_FSM	PDN_DLL	0C	
30		Reference								SEQEN	00	
31		Reference			ENREFR	VROI	VMIDSEL		VMIDLOW		28	
32		Reference			PDN_VREFGEN	PDN_IBIASGEN	LP_DACVRP	LP_VREFBUF	PDN_VREFBUF	VREFR_LO	34	
33		Reference	IBIASSW	VSEL								FC
34		Reference	MOUT_REF2	MOUT_REF1	OUT3_REF2	OUT3_REF1	OUT2_REF2	OUT2_REF1	OUT1_REF2	OUT1_REF1	55	
35		Reference					MONO_REF2	MONO_REF1	MIX_REF2	MIX_REF1	05	
36	PLL Setting	PLL Control	pdn	cp2	cp1	cp0	SupSel1	SupSel0	kvco1	kvco0	08	
37		PLL Control				LP	MCLKSEL	PLLOUT_DIV2	PLL_RB	PLL_EN	00	
38		PLL Control			DITH_MAG			PLL_N				00
39		PLL Control			PLL_K[21:16]							00
3A		PLL Control			PLL_K[15:8]							00
3B		PLL Control			PLL_K[7:0]							00
Adr		Name	Bit7	Bit6	Bit5	Bit4	Bit3	Bit2	Bit1	Bit0	default	
0	Output Setting	LOUT1 Volume	LP_OUT1	PDN_LOUT1			LOUT1VOL				40	
1		ROUT1 Volume		PDN_ROUT1			ROUT1VOL				40	
2		LOUT2 Volume	LP_OUT2	PDN_LOUT2			LOUT2VOL				40	
3		ROUT2 Volume		PDN_ROUT2			ROUT2VOL				40	



4		MOUT Volume	LP_MOUT	PDN_MOUT	MOUTVOL					40	
5		OUT Control 1	LP_OUT3	PDN_OUT3	OUT3SW		LP_ROUT2INV	ROUT2INV		40	
6		OUT Control 2						L2R2BOTH	L1R1BOTH	00	
7	Mixer Setting	Left Mixer	LI2LOMU	LI2LOVOL		MI2LOMU	MI2LOVOL			FF	
8		Right Mixer	MI2ROMU	MI2ROVOL		RI2ROMU	RI2ROVOL			FF	
9		Mono Mixer	LI2MOMU	LI2MOVOL		RI2MOMU	RI2MOVOL			FF	
A		DAC to Mixer	PDN_MONODIFF	DMEN	LD2MOMU	RD2MOMU	LD2LOMU	RD2LOMU	LD2ROMU	RD2ROMU	BF
B		Mixer LP mode					LP_MONODIFF	LP_MMIX	LP_LMIX	LP_RMIX	00
C	DAC Setting	Left DAC Volume	DACLVOL							C0	
D		Right DAC Volume	DACRVOL							C0	
E		DAC Control	LP_DACL	PDN_DACL	LP_DACR	PDN_DACR		DACLUMU		DACRMU	55
F		DAC Control	AUTOMUTE	CLICKFREE	VPPSCALE		DACLRBOTH	DACSOFTRAMP	DACRAMPRATE		C4
10		DAC Control			DACINVL	DACINVR	DACTOEN	DACDAT		08	
11		DAC Control			DACZEROL	DACZEROR	DACMONO	DACSE		00	
12					SHV1_A[29:24]					1F	
13		Shelving1_A			SHV1_A[23:16]					F7	
14					SHV1_A[15:8]					FD	
15					SHV1_A[7:0]					FF	
16						SHV1_B[29:24]					1F
17		Shelving1_B			SHV1_B[23:16]					F7	
18					SHV1_B[15:8]					FD	
19					SHV1_B[7:0]					FF	
1A						SHV2_A[29:24]					1F
1B		Shelving2_A			SHV2_A[23:16]					F7	
1C					SHV2_A[15:8]					FD	
1D					SHV2_A[7:0]					FF	
1E						SHV2_B[29:24]					1F
1F		Shelving2_B			SHV2_B[23:16]					F7	
20					SHV2_B[15:8]					FD	
21					SHV2_B[7:0]					FF	
22			Shelving3_A			SHV3_A[29:24]					1F
23					SHV3_A[23:16]					F7	
24					SHV3_A[15:8]					FD	

25			SHV3_A[7:0]							FF	
26				SHV3_B[29:24]							1F
27		Shelving3_B	SHV3_B[23:16]							F7	
28			SHV3_B[15:8]							FD	
29			SHV3_B[7:0]							FF	
2A	Digital Audio I/F Setting		Digital Interface	DACFORMAT		DACLRSWP		DACLRP	DACWL		00
2B		Digital Interface			MCLKDIV2		SCLKINV	FSMODE	DACMSC	01	
2C		Sample Rate			DACSR						06
2D		SCLK Divider			SCLKDIV						00
2E	Reference Setting	Reset	RST_CP							00	
2F		Power Down				PDN_ANA	PDN_DIG	PDN_FSM	PDN_DLL	0C	
30		Reference							SEQEN	00	
31		Reference		ENREFR	VROI	VMIDSEL		VMIDLOW		28	
32		Reference		PDN_VREFGEN	PDN_IBIASGEN	LP_DACVRP	LP_VREFBUF	PDN_VREFBUF	VREFR_LO	34	
33		Reference	IBIASSW	VSEL							FC
34		Reference	MOUT_REF2	MOUT_REF1	OUT3_REF2	OUT3_REF1	OUT2_REF2	OUT2_REF1	OUT1_REF2	OUT1_REF1	55
35		Reference					MONO_REF2	MONO_REF1	MIX_REF2	MIX_REF1	05
36	PLL Setting	PLL Control	pdn	cp2	cp1	cp0	SupSel1	SupSel0	kvco1	kvco0	08
37		PLL Control			LP	MCLKSEL	PLLOUT_DIV2	PLL_RB	PLL_EN	00	
38		PLL Control		DITH_MAG			PLL_N				00
39		PLL Control			PLL_K[21:16]						00
3A		PLL Control		PLL_K[15:8]							00
3B		PLL Control		PLL_K[7:0]							00

OUTPUT SETTINGS
Register 0 – LOUT1 Volume, Default 0100 0000

Bit Name	Bit	Description
LP_LOUT1	7	0 – normal (default) 1 – low power setting for LOUT1
PDN_LOUT1	6	0 – not power down 1 – power down LOUT1 (default)
LOUT1VOL	5:0	LOUT1 volume control 000000 – -45 dB (default) 000001 – -43.5 dB 000010 – -42 dB ... 011110 – 0 dB 011111 – 1.5 dB ... 100100 – 9 dB

Register 1 – ROUT1 Volume, Default 0100 0000

Bit Name	Bit	Description
LP_ROUT1	7	0 – normal (default) 1 – low power setting for ROUT1
PDN_ROUT1	6	0 – not power down 1 – power down ROUT1 (default)
ROUT1VOL	5:0	ROUT1 volume control 000000 – -45 dB (default) 000001 – -43.5 dB 000010 – -42 dB ... 011110 – 0 dB 011111 – 1.5 dB ... 100100 – 9 dB

Register 2 – LOUT2 Volume, Default 0100 0000

Bit Name	Bit	Description
LP_LOUT2	7	0 – normal (default) 1 – low power setting for LOUT2
PDN_LOUT2	6	0 – not power down 1 – power down LOUT2 (default)
LOUT2VOL	5:0	LOUT2 volume control 000000 – -45 dB (default) 000001 – -43.5 dB 000010 – -42 dB ... 011110 – 0 dB 011111 – 1.5 dB ... 100100 – 9 dB

Register 3 – ROUT2 Volume, Default 0100 0000

Bit Name	Bit	Description
LP_ROUT2	7	0 – normal (default) 1 – low power setting for ROUT2
PDN_ROUT2	6	0 – not power down 1 – power down ROUT2 (default)
ROUT2VOL	5:0	ROUT2 volume control 000000 – -45 dB (default) 000001 – -43.5 dB 000010 – -42 dB

		... 011110 – 0 dB 011111 – 1.5 dB ... 100100 – 9 dB
--	--	---

Register 4 – MOUT Volume, Default 0100 0000

Bit Name	Bit	Description
LP_MOUT	7	0 – normal (default) 1 – low power setting for Mono Out
PDN_MOUT	6	0 – not power down 1 – power down mono out (default)
MOUTVOL	5:0	Mono Out volume control 000000 – -45 dB (default) 000001 – -43.5 dB 000010 – -42 dB ... 011110 – 0 dB 011111 – 1.5 dB ... 100100 – 9 dB

Register 5 – Out Control 1, Default 0100 0000

Bit Name	Bit	Description
LP_OUT3	7	0 – normal (default) 1 – low power setting for OUT3
PDN_OUT3	6	0 – not power down 1 – power down OUT3 (default)
OUT3SW	5:4	OUT3 select 00 – VREF (default) 01 – ROUT1 signal 10 – MONOOUT 11 – right mixer output
LP_ROUT2INV	3	0 – normal (default) 1 – low power setting for ROUT2INV
ROUT2INV	2	0 – no Inversion (default) 1 – ROUT2 signal inverted

Register 6 – Out Control 2, Default 0000 0000

Bit Name	Bit	Description
L2R2BOTH	1	1 – simultaneous load of LOUT2VOL and ROUT2VOL 0 – disable simultaneous load (default)
L1R1BOTH	0	1 – simultaneous load of LOUT1VOL and ROUT1VOL 0 – disable simultaneous load (default)

MIXER SETTING
Register 7 – Left Mixer, Default 1111 1111

Bit Name	Bit	Description
LI2LOMU	7	1 – mute left line in to left out mixer (default) 0 – not mute
LI2LOVOL	6:4	Left line in to left out mixer volume control 000 – 6 dB 001 – 3 dB 010 – 0 dB 011 – -3 dB 100 – -6 dB 101 – -9 dB 110 – -12 dB

		111 – -15 dB (default)
MI2LOMU	3	1 – mute microphone in to left out mixer (default) 0 – not mute
MI2LOVOL	2:0	Microphone in to left out mixer volume control 000 – 6 dB 001 – 3 dB 010 – 0 dB 011 – -3 dB 100 – -6 dB 101 – -9 dB 110 – -12 dB 111 – -15 dB (default)

Register 8 – Right Mixer, Default 1111 1111

Bit Name	Bit	Description
MI2ROMU	7	1 –mute microphone in to right out mixer (default) 0 – not mute
MI2ROVOL	6:4	Microphone in to right out mixer volume control 000 – 6 dB 001 – 3 dB 010 – 0 dB 011 – -3 dB 100 – -6 dB 101 – -9 dB 110 – -12 dB 111 – -15 dB (default)
RI2ROMU	3	1 – mute right line in to right out mixer (default) 0 – not mute
RI2ROVOL	2:0	Right line in to rights out mixer volume control 000 – 6 dB 001 – 3 dB 010 – 0 dB 011 – -3 dB 100 – -6 dB 101 – -9 dB 110 – -12 dB 111 – -15 dB (default)

Register 9 – Mono Mixer, Default 1111 1111

Bit Name	Bit	Description
LI2MOMU	7	1 – mute left line in to mono out mixer (default) 0 – not mute
LI2MOVOL	6:4	Left line in to mono out mixer volume control 000 – 6 dB 001 – 3 dB 010 – 0 dB 011 – -3 dB 100 – -6 dB 101 – -9 dB 110 – -12 dB 111 – -15 dB (default)
RI2MOMU	3	1 – mute right line in to mono out mixer (default) 0 – not mute
RI2MOVOL	2:0	Right line in to mono out mixer volume control 000 – 6 dB 001 – 3 dB 010 – 0 dB 011 – -3 dB 100 – -6 dB 101 – -9 dB

		110 -- -12 dB 111 -- -15 dB (default)
--	--	--

Register 10 – DAC to Mixer, Default 1011 1111

Bit Name	Bit	Description
PDN_MONODIFF	7	1 – power down mono differential input stage (default) 0 – not power down
DMEN	6	1 – mono differential line in enable 0 – single-ended line in from MONO+ (default)
LD2MOMU	5	1 – mute left DAC to mono out mixer (default) 0 – not Mute
RD2MOMU	4	1 – mute right DAC to mono out mixer (default) 0 – not mute
LD2LOMU	3	1 – mute left DAC to left out mixer (default) 0 – not mute
RD2LOMU	2	1 – mute right DAC to left out mixer (default) 0 – not mute
LD2ROMU	1	1 – mute left DAC to right out mixer (default) 0 – not mute
RD2ROMU	0	1 – mute right DAC to right out mixer (default) 0 – not mute

Register 11 – Mixer LP Mode, Default 0000 0000

Bit Name	Bit	Description
LP_MONODIFF	3	0 – normal (default) 1 – low power setting for mono differential input stage
LP_MMXIX	2	0 – normal (default) 1 – low power setting for mono mixer
LP_LMIX	1	0 – normal (default) 1 – low power setting for left mixer
LP_RMIX	0	0 – normal (default) 1 – low power setting for right mixer

DAC SETTING
Register 12 – Left DAC Volume, Default 1100 0000

Bit Name	Bit	Description
DACLVOL	7:0	Left DAC volume control 00000000 – 0 dB ... 0.5 dB/step 11000000 – -127 dB (default)

Register 13 – Right DAC Volume, Default 1100 0000

Bit Name	Bit	Description
DACRVOL	7:0	Right DAC volume control 00000000 – 0 dB ... 0.5 dB/step 11000000 – -127 dB (default)

Register 14 – DAC Control 1, Default 0101 0101

Bit Name	Bit	Description
LP_DAACL	7	0 – normal (default) 1 – low power setting for left DAC
PDN_DAACL	6	0 – not power down 1 – power down left DAC (default)
LP_DACR	5	0 – normal (default) 1 – low power setting for right DAC
PDN_DACR	4	0 – not power down 1 – power down right DAC (default)

DACLMU	2	1 – left DAC mute (default) 0 – left DAC not mute
DACRMU	0	1 – right DAC mute (default) 0 – right DAC not mute

Register 15 – DAC Control 2, Default 1100 0100

Bit Name	Bit	Description
AUTOMUTE	7	Auto mute function: long period of zero inputs (8k audio samples) will mute the analog output. Any single non-zero input will un-mute. It is done per channel based. 0 – disable 1 – enable (default)
CLICKFREE	6	0 – disable digital click free power up and down 1 – enable digital click free power up and down (default)
VPPSCALE	5:4	Reserved
DACLRBOTH	3	1 – enable simultaneous load of DACLVOL and DACRVOL 0 – disable simultaneous load (default)
DACSOFTRAMP	2	1 – enable DAC soft ramp at mute and volume change (default) 0 – disable
DACRAMPRATE	1:0	These bits define DAC gain control ramp rate 00 – 0.5 dB per 4 LRCKs (default) 01 – 0.5 dB per 8 LRCKs 10 – 0.5 dB per 16 LRCKs 11 – 0.5 dB per 32 LRCKs

Register 16 – DAC Control 3, Default 0000 1000

Bit Name	Bit	Description
DACINVL	5	0 – DAC left channel output no phase inversion (default) 1 – DAC left channel output 180 degree phase inversion
DACINVR	4	0 – DAC right channel output no phase inversion (default) 1 – DAC right output 180 degree phase inversion
DACTOEN	3	Reserved
DACDAT	2	0 – disable DAC data 6 dB attenuate 1 – -6 dB enable

Register 17 – DAC Control 4, Default 0000 0000

Bit Name	Bit	Description
DACZEROL	5	0 – normal (default) 1 – set left channel DAC output all zero
DACZEROR	4	0 – normal (default) 1 – set right channel DAC output all zero
DACMONO	3	0 – stereo (default), and enable SE function 1 – mono ((L+R)/2) into DACL and DACR, and disable SE function
DACSE	2:0	Stereo enhancement gain 000 – 0 (default) 001 – 1/8 ... 111 – 7/8

Register 18 – SHELIVING1_A[29:24], Default 0001 1111

Bit Name	Bit	Description
SHEV1_A[29:24]	5:0	30-bit a coefficient for shelving filter; Default value is {5'h0f, 5'h1f, 5'h0f, 5'h1f, 5'h0f, 5'h1f}

Register 19 – SHELIVING1_A[23:16], Default 1111 0111

Bit Name	Bit	Description
SHEV1_A[23:16]	7:0	30-bit a coefficient for shelving filter; Default value is {5'h0f, 5'h1f, 5'h0f, 5'h1f, 5'h0f, 5'h1f}

Register 20 – SHELVING1_A[15:8], Default 1111 1101

Bit Name	Bit	Description
SHEV1_A[15:8]	7:0	30-bit a coefficient for shelving filter; Default value is {5'h0f, 5'h1f, 5'h0f, 5'h1f, 5'h0f, 5'h1f}

Register 21 – SHELVING1_A[7:0], Default 1111 1111

Bit Name	Bit	Description
SHEV1_A[7:0]	7:0	30-bit a coefficient for shelving filter; Default value is {5'h0f, 5'h1f, 5'h0f, 5'h1f, 5'h0f, 5'h1f}

Register 22 – SHELVING1_B[29:24], Default 0001 1111

Bit Name	Bit	Description
SHEV1_B[29:24]	5:0	30-bit a coefficient for shelving filter; Default value is {5'h0f, 5'h1f, 5'h0f, 5'h1f, 5'h0f, 5'h1f}

Register 23 – SHELVING1_B[23:16], Default 1111 0111

Bit Name	Bit	Description
SHEV1_B[23:16]	7:0	30-bit a coefficient for shelving filter; Default value is {5'h0f, 5'h1f, 5'h0f, 5'h1f, 5'h0f, 5'h1f}

Register 24 – SHELVING1_B[15:8], Default 1111 1101

Bit Name	Bit	Description
SHEV1_B[15:8]	7:0	30-bit a coefficient for shelving filter; Default value is {5'h0f, 5'h1f, 5'h0f, 5'h1f, 5'h0f, 5'h1f}

Register 25 – SHELVING1_B[7:0], Default 1111 1111

Bit Name	Bit	Description
SHEV1_B[7:0]	7:0	30-bit a coefficient for shelving filter; Default value is {5'h0f, 5'h1f, 5'h0f, 5'h1f, 5'h0f, 5'h1f}

Register 26 – SHELVING2_A[29:24], Default 0001 1111

Bit Name	Bit	Description
SHEV2_A[29:24]	5:0	30-bit a coefficient for shelving filter; Default value is {5'h0f, 5'h1f, 5'h0f, 5'h1f, 5'h0f, 5'h1f}

Register 27 – SHELVING2_A[23:16], Default 1111 0111

Bit Name	Bit	Description
SHEV2_A[23:16]	7:0	30-bit a coefficient for shelving filter; Default value is {5'h0f, 5'h1f, 5'h0f, 5'h1f, 5'h0f, 5'h1f}

Register 28 – SHELVING2_A[15:8], Default 1111 1101

Bit Name	Bit	Description
SHEV2_A[15:8]	7:0	30-bit a coefficient for shelving filter; Default value is {5'h0f, 5'h1f, 5'h0f, 5'h1f, 5'h0f, 5'h1f}

Register 29 – SHELVING2_A[7:0], Default 1111 1111

Bit Name	Bit	Description
SHEV2_A[7:0]	7:0	30-bit a coefficient for shelving filter; Default value is {5'h0f, 5'h1f, 5'h0f, 5'h1f, 5'h0f, 5'h1f}

Register 30 – SHELVING2_B[29:24], Default 0001 1111

Bit Name	Bit	Description
SHEV2_B[29:24]	5:0	30-bit a coefficient for shelving filter; Default value is {5'h0f, 5'h1f, 5'h0f, 5'h1f, 5'h0f, 5'h1f}

Register 31 – SHELVING2_B[23:16], Default 1111 0111

Bit Name	Bit	Description
SHEV2_B[23:16]	7:0	30-bit a coefficient for shelving filter; Default value is {5'h0f, 5'h1f, 5'h0f, 5'h1f, 5'h0f, 5'h1f}

Register 32 – SHELVING2_B[15:8], Default 1111 1101

Bit Name	Bit	Description
SHEV2_B[15:8]	7:0	30-bit a coefficient for shelving filter; Default value is {5'h0f, 5'h1f, 5'h0f, 5'h1f, 5'h0f, 5'h1f}

Register 33 – SHELVING2_B[7:0], Default 1111 1111

Bit Name	Bit	Description

SHEV2_B[7:0]	7:0	30-bit a coefficient for shelving filter; Default value is {5'h0f, 5'h1f, 5'h0f, 5'h1f, 5'h0f, 5'h1f}
--------------	-----	---

Register 34 – SHELIVING3_A[29:24], Default 0001 1111

Bit Name	Bit	Description
SHEV3_A[29:24]	5:0	30-bit a coefficient for shelving filter; Default value is {5'h0f, 5'h1f, 5'h0f, 5'h1f, 5'h0f, 5'h1f}

Register 35 – SHELIVING3_A[23:16], Default 1111 0111

Bit Name	Bit	Description
SHEV3_A[23:16]	7:0	30-bit a coefficient for shelving filter; Default value is {5'h0f, 5'h1f, 5'h0f, 5'h1f, 5'h0f, 5'h1f}

Register 36 – SHELIVING3_A[15:8], Default 1111 1101

Bit Name	Bit	Description
SHEV3_A[15:8]	7:0	30-bit a coefficient for shelving filter; Default value is {5'h0f, 5'h1f, 5'h0f, 5'h1f, 5'h0f, 5'h1f}

Register 37 – SHELIVING3_A[7:0], Default 1111 1111

Bit Name	Bit	Description
SHEV3_A[7:0]	7:0	30-bit a coefficient for shelving filter; Default value is {5'h0f, 5'h1f, 5'h0f, 5'h1f, 5'h0f, 5'h1f}

Register 38 – SHELIVING3_B[29:24], Default 0001 1111

Bit Name	Bit	Description
SHEV3_B[29:24]	5:0	30-bit a coefficient for shelving filter; Default value is {5'h0f, 5'h1f, 5'h0f, 5'h1f, 5'h0f, 5'h1f}

Register 39 – SHELIVING3_B[23:16], Default 1111 0111

Bit Name	Bit	Description
SHEV3_B[23:16]	7:0	30-bit a coefficient for shelving filter; Default value is {5'h0f, 5'h1f, 5'h0f, 5'h1f, 5'h0f, 5'h1f}

Register 40 – SHELIVING3_B[15:8], Default 1111 1101

Bit Name	Bit	Description
SHEV3_B[15:8]	7:0	30-bit a coefficient for shelving filter; Default value is {5'h0f, 5'h1f, 5'h0f, 5'h1f, 5'h0f, 5'h1f}

Register 41 – SHELIVING3_B[7:0], Default 1111 1111

Bit Name	Bit	Description
SHEV3_B[7:0]	7:0	30-bit a coefficient for shelving filter; Default value is {5'h0f, 5'h1f, 5'h0f, 5'h1f, 5'h0f, 5'h1f}

DIGITAL AUDIO INTERFACE SETTING
Register 42 – Digital Audio Interface 1, Default 0000 0000

Bit Name	Bit	Description
DACFORMAT	7:6	Audio data format 00 – I2S format (default) 01 – left justify 10 – right justify, 11 – DSP mode
DACLRSWP	5:4	00 – left data = left DAC, right data = right DAC (default) 01 – left data = left DAC, right data = left DAC 10 – left data = right DAC, right data = right DAC 11 – left data = right DAC, right data = left DAC
DACLRP	3	I2S/left justified/right justified case: 0 – L/R normal polarity (default) 1 – L/R invert polarity DSP mode case: 0 – Mode A, MSB is available on 2 nd SCLK rising edge after LRCK rising edge 1 – Mode B, MSB is available on 1 st SCLK rising edge after LRCK rising edge
DACWL	2:0	Data word length 000 – 24-bit (default) 001 – 20-bit

		010 – 18-bit 011 – 16-bit 100 – 32-bit
--	--	--

Register 43 – Digital Audio Interface 2, Default 0000 0001

Bit Name	Bit	Description
MCLKDIV2	4	0 – chip clock is MCLK (default) 1 – chip clock is MCLK divide by 2
SCLKINV	2	0 – normal (default) 1 – SCLK inverted
FSMODE	1	0 – single speed mode (default) 1 – double speed mode
DACMSC	0	1 – master mode serial port (default) 0 – slave mode serial port

Register 44 – Digital Audio Sample Rate, Default 0000 0110

Bit Name	Bit	Description
DACSR	4:0	DAC sample rate, MCLK frequency/LRCK frequency 00000 – 128 00001 – 192 00010 – 256 00011 – 384 00100 – 512 00101 – 576 00110 – 768 (default) 00111 – 1024 01000 – 1152 01001 – 1408 01010 – 1536 01011 – 2112 01100 – 2304 10000 – 125 10001 – 136 10010 – 250 10011 – 272 10100 – 375 10101 – 500 10110 – 544 10111 – 750 11000 – 1000 11001 – 1088 11010 – 1496 11011 – 1500 Other – Reserved

Register 45 – SCLK Divider, Default 0000 0000

Bit Name	Bit	Description
SCLKDIV	4:0	SCLK divider 0 – divide depend on DACSR and clock frequency 1 – divide by 1 2 – divide by 2 3 – divide by 3 4 – divide by 4 5 – divide by 6 6 – divide by 8 7 – divide by 9 8 – divide by 11 9 – divide by 12 10 – divide by 16 11 – divide by 18 12 – divide by 22 13 – divide by 24 14 – divide by 33 15 – divide by 36 16 – divide by 44 17 – divide by 48

		18 – divide by 66 19 – divide by 72 other – divide by 4
--	--	---

REFERENCE SETTING
Register 46 – Control Port Registers Reset, Default 0000 0000

Bit Name	Bit	Description
RST_CP	7	0 – not reset (default) 1 – reset all registers of control port

Register 47 – Power Down Control, Default 0000 1100

Bit Name	Bit	Description
PDN_ANA	3	0 – not power down 1 – power down analog blocks (default)
PDN_DIG	2	0 – not power down 1 – power down digital blocks (default)
PDN_FSM	1	0 – not power down (default) 1 – power down FSM
PDN_DLL	0	0 – not power down (default) 1 – power down DLL

Register 48 – Reference 1, Default 0000 0000

Bit Name	Bit	Description
SEQ_EN	0	0 – internal power up/down sequence disable (default) 1 – internal power up/down sequence enable

Register 49 – Reference 2, Default 0010 1000

Bit Name	Bit	Description
ENREFR	5	0 – disable reference 1 – enable reference (default)
VROI	4	0 – 1.5k Ω VREF to analog output resistance (default) 1 – 40k Ω VREF to analog output resistance
VMIDSEL	3:2	00 – Vmid disabled (off mode) 01 – 50k Ω divider enabled (playback/record mode) 10 – 500k Ω divider enabled (standby mode, default) 11 – 5 k Ω divider enabled (fast start-up mode)
VMIDLOW	1:0	Reserved

Register 50 – Reference 3, Default 0011 0100

Bit Name	Bit	Description
PDN_VREFGEN	5	0 – not power down 1 – power down VREFGEN (default)
PDN_IBIASGEN	4	0 – not power down 1 – power down IBIASGEN (default)
LP_DACVRP	3	0 – normal (default) 1 – low power mode for DACVRP
LP_VREFBUF	2	0 – normal 1 – low power for VREFBUF (default)
PDN_VREFBUF	1	0 – not power down (default) 1 – power down VREFBUF
VREFR_LO	0	0 – normal (default) 1 – low power for VREFR

Register 51 – Reference 4, Default 1111 1100

Bit Name	Bit	Description
IBIASSW	7	Reserved

VSEL	6:0	Reserved
------	-----	----------

Register 52 – Reference 5, Default 0101 0101

Bit Name	Bit	Description
MOUT_REF2	7	Reserved
MOUT_REF1	6	Reserved
OUT3_REF2	5	Reserved
OUT3_REF1	4	Reserved
OUT2_REF2	3	Reserved
OUT2_REF1	2	Reserved
OUT1_REF2	1	Reserved
OUT1_REF1	0	Reserved

Register 53 – Reference 6, Default 0000 0101

Bit Name	Bit	Description
MONO_REF2	3	Reserved
MONO_REF1	2	Reserved
MIX_REF2	1	Reserved
MIX_REF1	0	Reserved

PLL SETTING
Register 54 – PLL Control 1, Default 0000 1000

Bit Name	Bit	Description
pdn	7	0 – not power down (default) 1 – power down PLL analog
cp2	6	Reserved
cp1	5	Reserved
cp0	4	Reserved
SupSel1	3	Reserved
SupSel0	2	Reserved
kvco1	1	Reserved
kvco0	0	Reserved

Register 55 – PLL Control 2, Default 0000 0000

Bit Name	Bit	Description
LP	4	0 – normal mode (default) 1 – low power mode for PLL analog
MCLKSEL	3	Select internal master clock 0 – from MCLK pin (default) 1 – from PLL (to use PLL, make sure PLEN=1, PLL_RB=1, otherwise, the setting will close chip clock)
PLLOUT_DIV2	2	0 – divide disabled, PLL out clock is vcoout/4 (default) 1 – divide enabled, PLL out clock is vcoout/8
PLL_RB	1	0 – PLL held in reset (default) 1 – PLL running (if PLEN=1)
PLL_EN	0	0 – PLL disabled (default) 1 – PLL enabled

Register 56 – PLL Control 3, Default 0000 0000

Bit Name	Bit	Description
DITH_MAG	6:4	Reserved
PLL_N	3:0	Integer part of PLL input/output frequency ratio; Use value greater than 5 and less than 13

Register 57 – PLL_K[21:16], Default 0000 0000

Bit Name	Bit	Description
PLL_K[21:16]	5:0	Fractional part of PLL input/output frequency ratio (treat as one 22-digital binary number)

Register 59 – PLL_K[15:8], Default 0000 0000

Bit Name	Bit	Description
PLL_K[15:8]	7:0	Fractional part of PLL input/output frequency ratio (treat as one 22-digital binary number)

Register 60 – PLL_K[7:0], Default 0000 0000

Bit Name	Bit	Description
PLL_K[7:0]	7:0	Fractional part of PLL input/output frequency ratio (treat as one 22-digital binary number)

DIGITAL AUDIO INTERFACE

The device provides four formats of serial audio data interface to the input of the DAC through LRCK, SCLK and SDIN pins. The four formats are I²S, left justified, right justified and DSP/PCM mode. DAC input DSDIN is sampled by PA5155 on the rising edge of DSCLK. The relationship of SDATA (SDIN), SCLK and LRCK with the three formats is shown through Figure 3 to Figure 7.

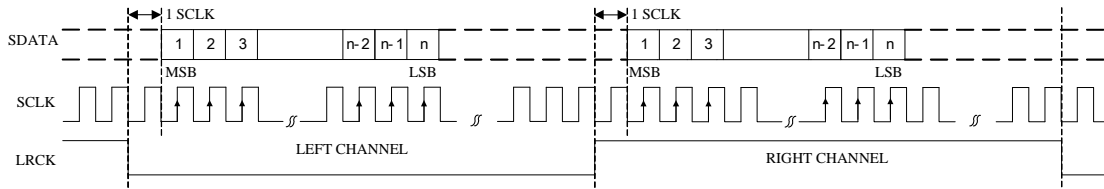

Figure 3 I²S Serial Audio Data Format Up To 24-bit

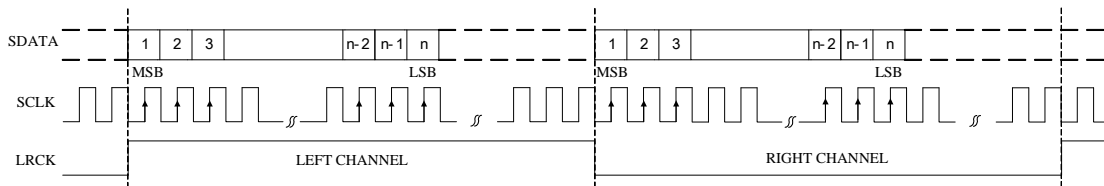

Figure 4 Left Justified Serial Audio Data Format Up To 24-bit

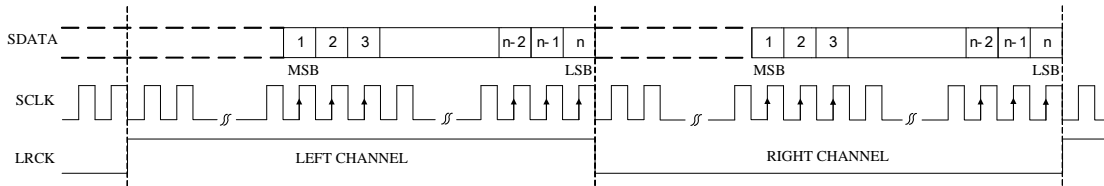

Figure 5 Right Justified Serial Audio Data Format Up To 24-bit

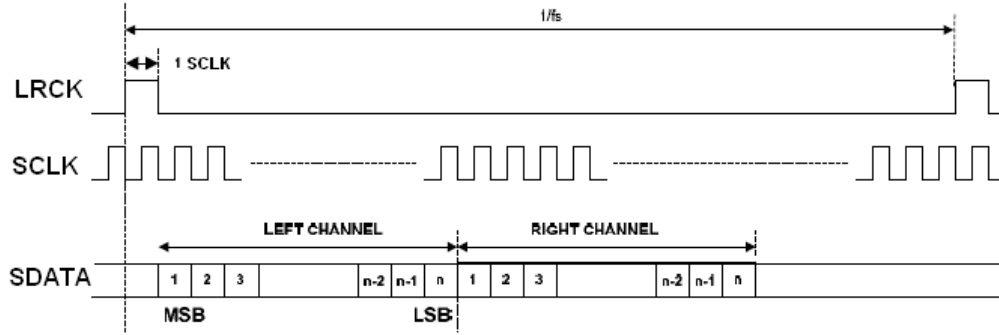

Figure 6 DSP/PCM Mode A

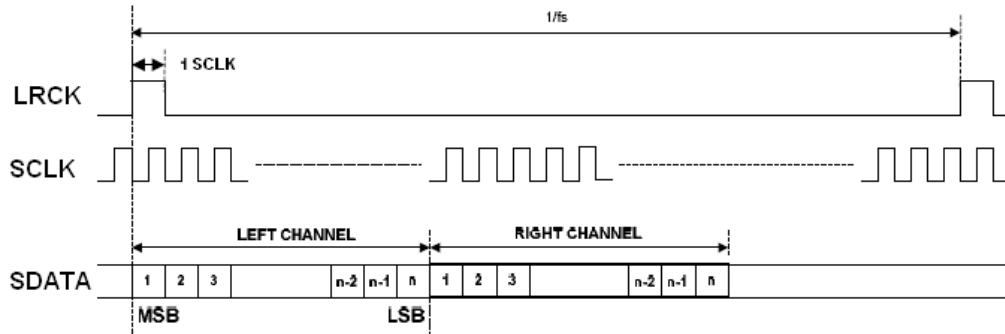
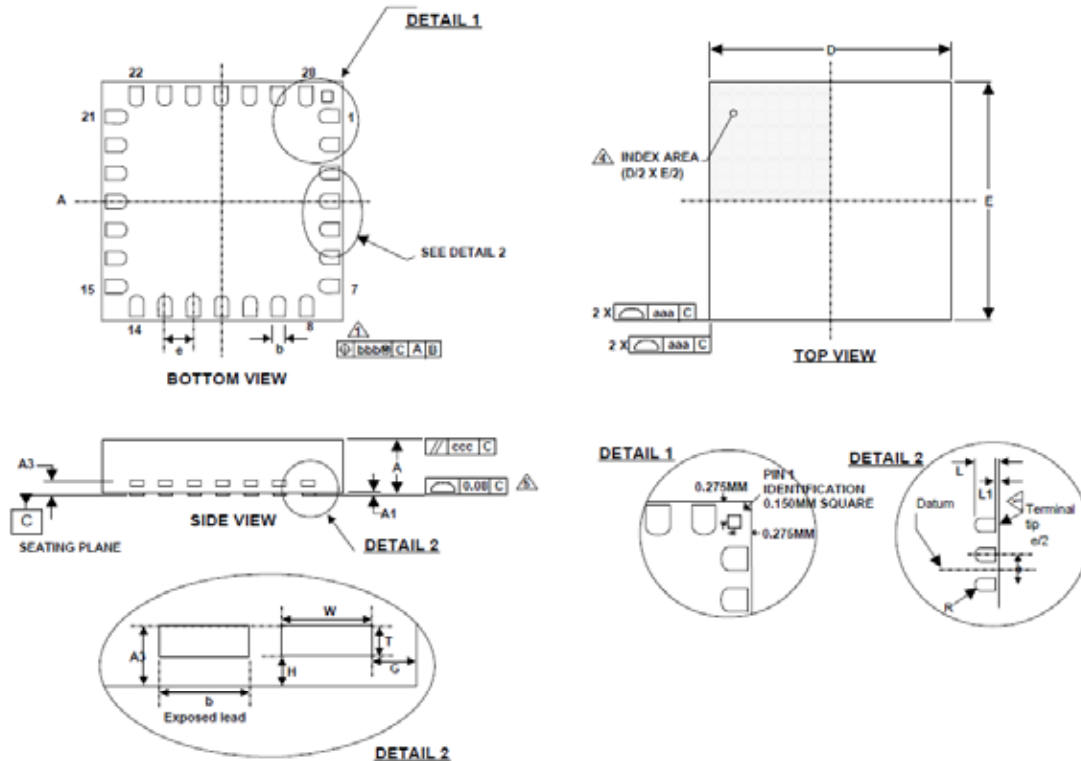

Figure 7 DSP/PCM Mode B

PACKAGE DIMENSIONS AND MEASUREMENTS



Symbols	Dimensions (mm)			
	MIN	NOM	MAX	NOTE
A	0.725	0.75	0.775	
A1	0	0.02	0.05	
A3		0.203 REF		
b	0.18	0.23	0.28	1
D	3.95	4.00	4.05	
E	3.95	4.00	4.05	
e		0.45 BSC		
G		0.535 REF		
H		0.100 REF		
L		0.40 REF		
L1		0.05 REF		7
T		0.100 REF		
W		0.230 REF		
Tolerances of Form and Position				
aaa		0.15		
bbb		0.10		
ccc		0.10		
REF:		JEDEC, MO-220		

Life Support Policy

PROTEK ANALOG'S PRODUCTS ARE NOT AUTHORIZED FOR USE AS CRITICAL COMPONENTS IN LIFE SUPPORT DEVICES OR SYSTEMS WITHOUT THE EXPRESS WRITTEN APPROVAL OF THE PRESIDENT OF PROTEK DEVICES.

